

Reflection Water Level Gauge type 17/215L, PN 40 with one sight length, rotatable glassholder with pressure frame

The liquid water level gauges type 17/215L are universal reflection gauges for heating and refrigeration as well as for storage vessels. Reflection water level gauges are equipped with sight glasses with grooves for a clear contrast in the display.

Design

The water level gauges type 17/215L are designed in accordance to the relevant German rules (TRD, AD, DIN).

Technical data

- glass holder in front with grooved reflex sight glasses
- glass size 2 up to 9 according to DIN 7081
- quick closing valves type 17/1 valve pass 8 mm

Process connection

- flange DN 20-25/PN 40, form C or ANSI
- drain valve 17/500, PN40, sleeve G 3/8" - DIN ISO 228
- vent plug M 12 x 12 mm, DIN 910

Material

- glass holder and pressure frame made of steel mat. 1.0460
- valve housing and connection flanges made of steel mat. 1.0460
- housing drain valve made of steel mat. 1.0570
- shut-off parts made of stainless steel mat.. 1.4104 + 1.4305
- reflection glass made of borosilicate, gaskets free of asbestos (graphite with sheet inlay)

Additional equipment

- automatically closing ball for shut-off valves (safety device) (min. 1 bar overpressure necessary for function)
- mica protection outside for protection in outdoor installations
- NW-mark for lowest water level acc. TRD
- rope hand wheels

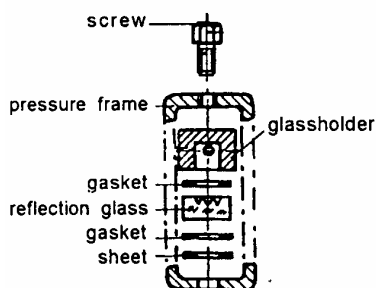
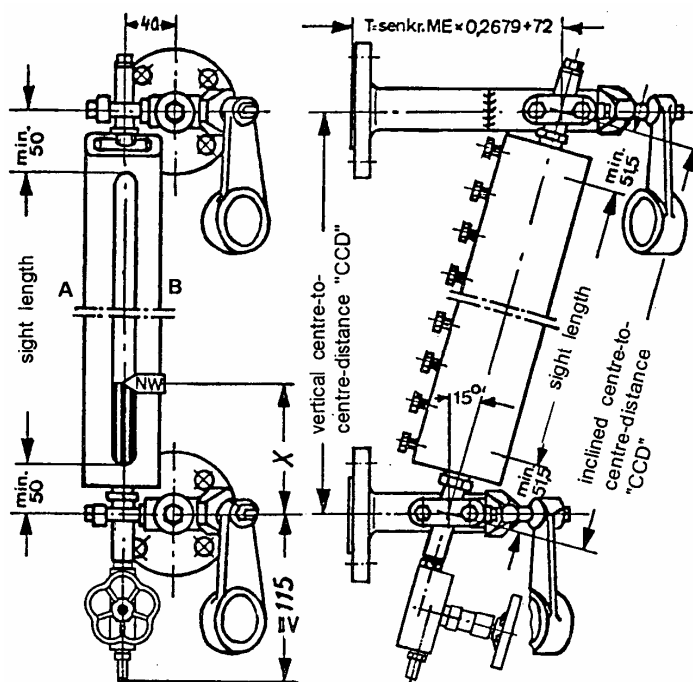

section A - B

drain valve type 17/500
(sleeve G 3/8"):

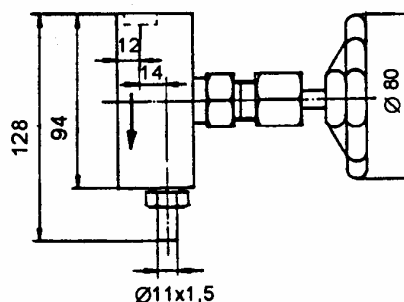

Reflection Water Level Gauge type 17/215L, PN 40 with one sight length, rotatable glassholder with pressure frame

Table glass size / range of center to center distance

glass size*	2	3	4	5	6	7	8	9
glass length (mm)	140	165	190	220	250	280	320	340
sight length (mm)	120	145	170	200	230	260	300	320
vertical CCD** from up to	215,5 240	239,5 265	263,5 300	292,5 325	321,5 355	350,5 395	389,5 410	408,5 440
inclined CCD**	$L = \frac{\text{vertical CCD}}{0,9659}$							
inclination	15 °							

* reflection glass DIN 7081, width = 34 mm, thickness = 17 mm, size 10 - 15 on request

** CCD = center to center distance in mm

conditions:

nominal pressure: PN 40	
operating temperature	operating overpressure
-10 up to 120 °C	40 bar
-10 up to 238 °C	32 bar
max. limit for reflection glass DIN 7081 = 243 °C	

arrangement:

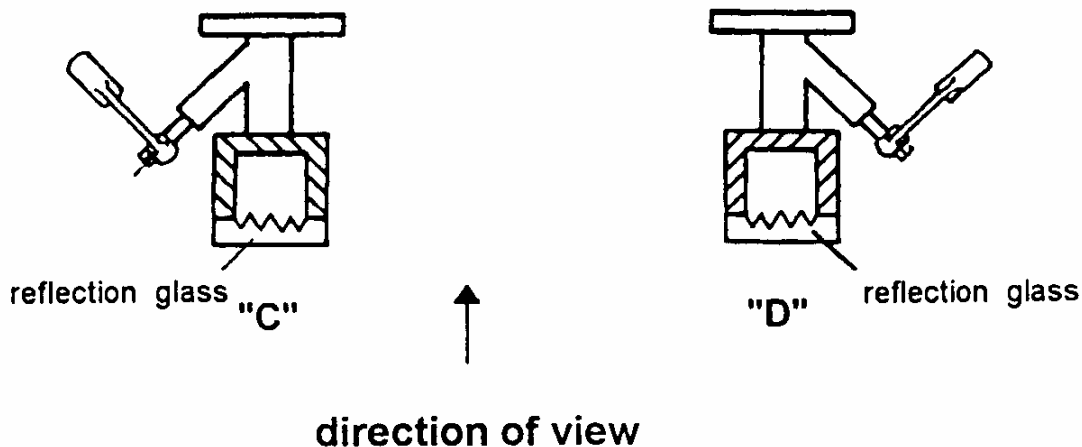

Order data

straight CCD, inclined CCD, flange size, arrangement, glass size, operating pressure, operating temperature, fluid, additional equipment