

www.phoenix-mt.com
PHÖNIX Messtechnik GmbH

AVEMAR

PHÖNIX MESSTECHNIK GMBH
VAIHINGER NIVEAU TECHNIK

Magnetic level gauge, PN 400/CL2500

Magnetic indicating bar scale with fine resolution, indirect level indication
Fully closed housing with gapless weldings
Float magnet field totally circular with strong far field
Float defect control with indication in lower display end

Product group **710**

Variant **760100**

Sheet: 1/2

Revision: 2

Date:

11/2010

II 1/2G c T1...T6
 DGRL 97/23/EG

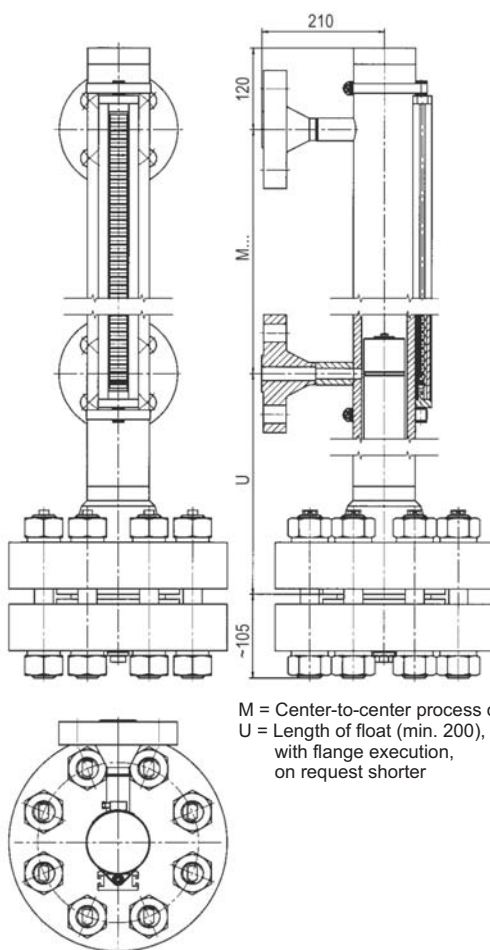

Measures in mm

Field of Application

The magnetic level gauge is for indicating the level height of liquids in any vessel via bypass. Simultaneously you can use level switches (s. 740.XXXX) or level sensors (s. 745.XXXX) mounted onto the reference vessel tube to signal level limits or measure the level height by remote means.

General Data

Density: from 0.54 g/cm³
Precision for Interface or density: from ±0.1 g/cm³
Measuring range (=M): 150 to 6000 mm,
from 3000 mm holding bracket each 1500 mm
Measuring error: ±10 mm
Viscosity: max 1000 mPas
Display type: 710.AVVX
Tube: Ø76 x10 mm
Connection: weld end or thread
flanges DIN10...25 up to PN400
flanges ANSI 1/2" ... 2 1/2" up to CLASS 2500
Drain/vent: plug G1/2", G3/4", NPT1/2", NPT3/4"/cap
vent DN8 PN400 G1/2", NPT1/2"/cap
flanges DIN10...25 up to PN400
flanges ANSI 1/2" ... 2 1/2" up to CLASS 2500
weld end 1/2"

Material

- tube, stud,
flanges, fixtures: Stainless steel, ANSI-coded
optional Titanium, Hastelloy
- float: Titanium
Weight: Basic 42 kg/+ 1,77 kg/100mm M

Design Data

Operating pressure: up to 40.0 MPa/2500 lbs
(according to design)
Temperature process: -160 ... +450 °C
(according to design)
T1/T2/T3/T4/T5/T6: 320/240/160/108/80/68 °C
Temperature ambient T1...T5/T6: -50 ... +80/+68 °C

Certificates

Pressure Vessel Directive (PED) 97/23/EG
EC-Type Examination KEMA 10 ATEX 0172 X
Certificate: Zone 0
Subject to alterations

Ordering no.

Ordering example:

710.760100

The ordering details are given in 710.TYPECODE

AVEMAR

AVEMAR cz s.r.o.
Lihovarská 1199/10
716 00 Ostrava-Radvanice
Tel.: +420 596 232 996(7)
Fax: +420 596 232 998
E-mail: avemar@avemar.cz
www.avemar.cz

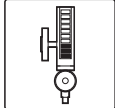

www.phoenix-mt.com
PHÖNIX Messtechnik GmbH



PHÖNIX MESSTECHNIK GMBH
VAIHINGER NIVEAU TECHNIK

Details

Float, Vent, Drain and Connection

Product group **710**

Variant **760100**

Sheet: 2/2

Revision: 2

Date:

11/2010

Float material Titanium 3.7035, Ø51, PN100, up to 200 °C

Density range / g/cm ³	Total length L / mm	Order no.
1,10 ... 1,38	150	BGZTS1501048
0,94 ... 1,12	185	BGZTS1851048
0,83 ... 0,94	225	BGZTS2251048
0,76 ... 0,83	275	BGZTS2751048
0,70 ... 0,76	330	BGZTS3301048
0,66 ... 0,70	400	BGZTS4001048
0,63 ... 0,66	435	BGZTS4351048
0,60 ... 0,63	525	BGZTS5251048
0,58 ... 0,60	625	BGZTS6251048

Float material titanium 3.7035, Ø51, PN100, up to 250 °C

Density range / g/cm ³	Total length L / mm	Order no.
1,27 ... 1,58	150	BGZTS1501092
1,09 ... 1,29	180	BGZTS1801092
0,96 ... 1,11	205	BGZTS2051092
0,86 ... 0,96	245	BGZTS2451092
0,79 ... 0,85	295	BGZTS2951092
0,73 ... 0,78	350	BGZTS3501092
0,69 ... 0,73	415	BGZTS4151092
0,66 ... 0,69	495	BGZTS4951092
0,63 ... 0,65	535	BGZTS5351092
0,60 ... 0,63	625	BGZTS6251092

Density range corresponds to measuring error ±10 mm
Interface float on request, higher pressure and temperature on request

Design Data

Operating pressure: up to 10.0 MPa/600 lbs
Test pressure: operating pressure x 1.3
Operating temperature: -30 ... +250 °C
higher temperatures on request

Subject to alterations

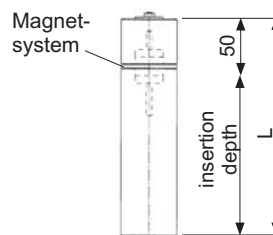
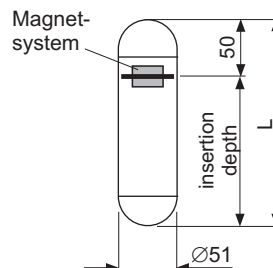

Solid body material
leakage-proof
max. operating
pressure 420 bar
max. operation
temperature 100 °C
order-no.
ZCFS...
on request

Vent

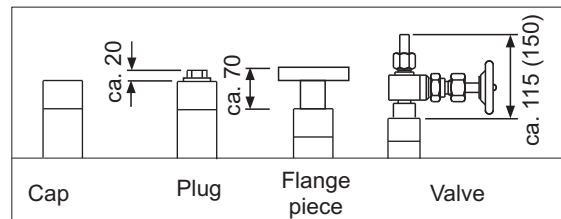

Drain

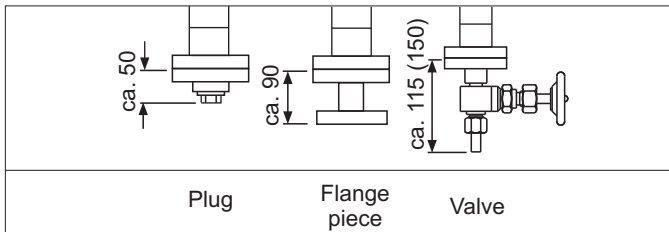

Connections

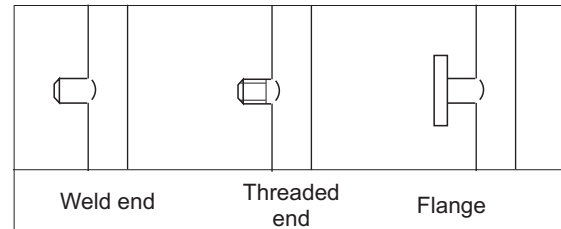

Ordering no.

Accessories:

Device	Product group
Magnetic switch	740.XXXX
Level sensor	745.XXXX
Indicating scale	710.AVGX
Frost protection	710.PLEXI
Heating	710.HEAT

Spare parts:

Designation	Part no.
Float	s. Float table above
Indicating scale	BG10.AVGX
Sealing	04750395XXX
Fixing springs	3813000672
Align magnet	BG10XXXXMAKU

There may be any other customer specified connections, materials and special floats.



AVEMAR cz s.r.o.
Lihovarská 1199/10
716 00 Ostrava-Radvanice
Tel.: +420 596 232 996(7)
Fax: +420 596 232 998
E-mail: avemar@avemar.cz
www.avemar.cz