

www.phoenix-mt.com  
PHÖNIX Messtechnik GmbH

**AVEMAR**

PHÖNIX MESSTECHNIK GMBH  
VAIHINGER NIVEAU TECHNIK

## Magnetic level gauge, PN 100/CL600

Magnetic indicating bar scale with fine resolution, indirect level indication  
Indicating elements permanent magnetic  
Fully closed housing with gapless weldings  
Float magnet field totally circular with strong far field

Product group **710**

Variant **650035**

Sheet: 1/2

Revision: 2

Date:

11/2010

II 1/2G c T1...T6  
 DGRL 97/23/EG

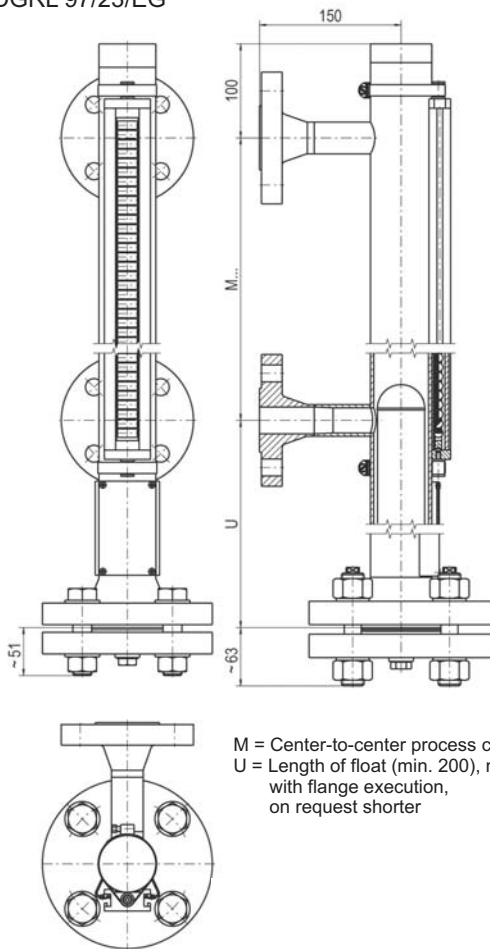

Measures in mm

### Field of Application

The magnetic level gauge is for indicating the level height of liquids in any vessel via bypass. Simultaneously you can use level switches (s. 740.XXXX) or level sensors (s. 745.XXXX) mounted onto the reference vessel tube to signal level limits or measure the level height by remote means.

### General Data

Density: from 0.50 g/cm<sup>3</sup>  
Precision for Interface or density: from ±0.1 g/cm<sup>3</sup>  
Measuring range (=M): 150 to 6000 mm, from 3000 mm holding bracket each 1500 mm  
Measuring error: ±10 mm  
Viscosity: max 1000 mPas  
Display type: 710.AVVX  
Tube: Ø65x3.5 mm  
Connection: weld end or thread  
flanges DIN10...25 up to PN100  
flanges ANSI 1/2" ... 3" up to CLASS 600  
Drain/vent: Welding cap or flat top or flanged (Chamber end top)  
plug G1/2", G3/4", NPT1/2", NPT3/4"/cap  
vent DN8 PN400 G1/2", NPT1/2"/cap  
flanges DIN10...25 up to PN100  
flanges ANSI 1/2" ... 2" up to CLASS 600  
weld end 1/2"

Material  
- tube, stud, flanges, fixtures: Stainless steel, ANSI-coded optional Titanium, Hastelloy  
- float: Titanium  
Weight: Basic 13 kg + 0,67 kg per 100mm M

### Design Data

Operating pressure: up to 10.0 MPa/600 lbs (according to design)  
Temperature process: -160 ... +450 °C (according to design)  
T1/T2/T3/T4/T5/T6: 320/240/160/108/80/68 °C  
Temperature ambient T1...T5/T6: -50 ... +80/+68 °C

### Certificates

Pressure Vessel Directive (PED) 97/23/EG  
EC-Type Examination KEMA 10 ATEX 0172 X  
Certificate: Zone 0  
Subject to alterations

Ordering no.

**710.650035**

The ordering details are given in 710.TYPECODE

**AVEMAR**

AVEMAR cz s.r.o.  
Lihovarská 1199/10  
716 00 Ostrava-Radvanice  
Tel.: +420 596 232 996(7)  
Fax: +420 596 232 998  
E-mail: avemar@avemar.cz  
www.avemar.cz

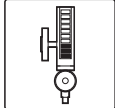

## Details

Float, Vent, Drain and Connection

Product group **710**

Variant **650035**

Sheet: 2/2

Revision: 2

Date:

11/2010

### Float material titanium 3.7035, Ø51, PN64, up to 200 °C

Density range / g/cm <sup>3</sup>	Total length L / mm	Order no.
1,03 ... 1,28	150	BGZTS1500648
0,88 ... 1,03	180	BGZTS1800648
0,77 ... 0,87	215	BGZTS2150648
0,69 ... 0,76	260	BGZTS2600648
0,63 ... 0,68	315	BGZTS3150648
0,58 ... 0,62	370	BGZTS3700648
0,55 ... 0,57	445	BGZTS4450648
0,52 ... 0,54	515	BGZTS5150648
0,50 ... 0,52	605	BGZTS6050648

### Float material titanium 3.7035, Ø51, PN64, up to 250 °C

Density range / g/cm <sup>3</sup>	Total length L / mm	Order no.
1,19 ... 1,48	150	BGZTS1500692
1,00 ... 1,18	180	BGZTS1800692
0,88 ... 1,00	215	BGZTS2150692
0,78 ... 0,87	255	BGZTS2550692
0,71 ... 0,78	295	BGZTS2950692
0,66 ... 0,70	350	BGZTS3500692
0,61 ... 0,65	405	BGZTS4050692
0,58 ... 0,61	470	BGZTS4700692
0,55 ... 0,57	555	BGZTS5550692

### Float material titanium 3.7035, Ø51, PN100, up to 200 °C

Density range / g/cm <sup>3</sup>	Total length L / mm	Order no.
1,10 ... 1,38	150	BGZTS1501048
0,94 ... 1,12	185	BGZTS1851048
0,83 ... 0,94	225	BGZTS2251048
0,76 ... 0,83	275	BGZTS2751048
0,70 ... 0,76	330	BGZTS3301048
0,66 ... 0,70	400	BGZTS4001048
0,63 ... 0,66	435	BGZTS4351048
0,60 ... 0,63	525	BGZTS5251048
0,58 ... 0,60	625	BGZTS6251048

### Float material titanium 3.7035, Ø51, PN100, up to 250 °C

Density range / g/cm <sup>3</sup>	Total length L / mm	Order no.
1,27 ... 1,58	150	BGZTS1501092
1,09 ... 1,29	180	BGZTS1801092
0,96 ... 1,11	205	BGZTS2051092
0,86 ... 0,96	245	BGZTS2451092
0,79 ... 0,85	295	BGZTS2951092
0,73 ... 0,78	350	BGZTS3501092
0,69 ... 0,73	415	BGZTS4151092
0,66 ... 0,69	495	BGZTS4951092
0,63 ... 0,65	535	BGZTS5351092
0,60 ... 0,63	625	BGZTS6251092

Density range corresponds to measuring error ±10 mm  
Interface float on request, higher pressure and temperature on request

## Design Data

Operating pressure: up to 10.0 MPa/600 lbs  
Test pressure: operating pressure x 1.3  
Operating temperature: -30 ... +250 °C  
higher temperatures on request  
Subject to alterations

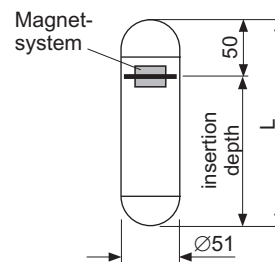

### Vent

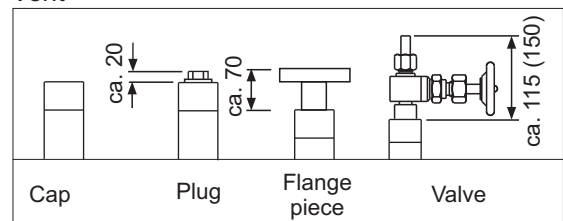

### Drain

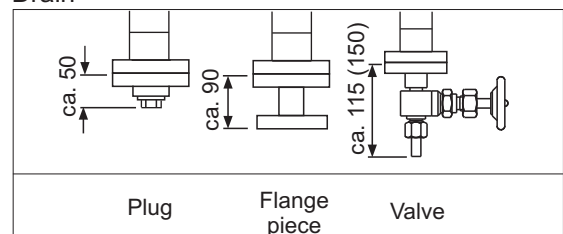

### Connections

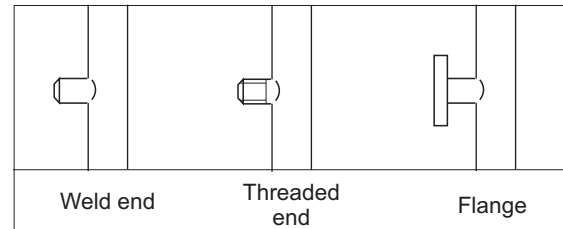

## Ordering no.

### Accessories:

Device	Product group
Magnetic switch	740.XXXX
Level sensor	745.XXXX
Indicating scale	710.AVGX
Frost protection	710.PLEXI
Heating	710.HEAT

### Spare parts:

Designation	Part no.
Float	s. Float table above
Indicating scale	BG10.AVGX
Sealing	04750395XXX
Fixing springs	3813000672
Align magnet	BG10XXXXMAKU

There may be any other customer specified connections, materials and special floats.



**AVEMAR cz s.r.o.**  
Lihovarská 1199/10  
716 00 Ostrava-Radvanice  
Tel.: +420 596 232 996(7)  
Fax: +420 596 232 998  
E-mail: avemar@avemar.cz  
www.avemar.cz