

## Magnetic Level Gauge PN 400/CL 2500

Magnetic indicating bar scale with fine resolution, indirect level indication  
 Indicating scale below containment  
 Indicating elements permanent magnetic with stop pin  
 Float magnet field totally circular with strong far field  
 Float defect control with indication in lower display end

Product group **710**

Type **32X.0**

Sheet: 1/1 Revision: 0

Date: 09/03

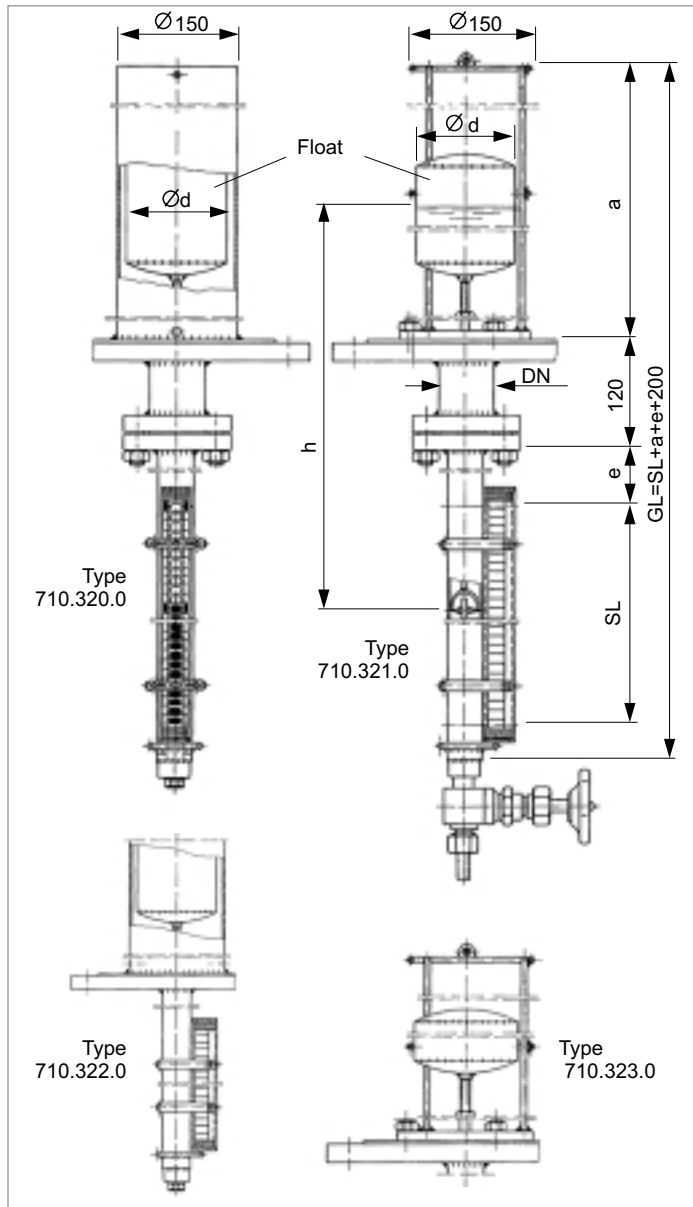

### Field of Application

The magnetic level gauge is for indicating the level height or interface of liquids in any vessel. Simultaneously you can use level switches (s. 740.XXXX) or level sensors (s. 745.XXXX) mounted onto the gauge tube to signal level limits or measure the level height by remote control.

### General Data

Density .320/1/2/3: from 0,7/0,6/0,7/0,7 g/cm<sup>3</sup>  
 Interface/difference of density: from ±0,1 g/cm<sup>3</sup>  
 Sight length SL .320/1: <1000 mm  
 .322/3: from 1000 mm  
 Accuracy: ±10 mm  
 Viscosity: max 1000 mPas  
 Display type: 710.AVG3  
 Connection: flange-piece or direct  
 Drain: plug 1/2" NPT/cap  
 optional 3/4" NPT, G1/2A, G3/4A,  
 Flange stud DIN and ANSI  
 Valve ND8, optional ND6,  
 and acc. to customer spec.  
 DN min .320/1/2/3: 40/65/100/125  
 Material tube, flanges, fixtures, guide: SS 1.4571  
 optional, Hastelloy, Titanium etc  
 DIN + ANSI-materials  
 Float: 1.4571, titanium  
 Float Ød .320/1/2/3: 40/56/85/108 mm  
 Weight .320/1/2/3: Basic  
 22,77/18,27/16,77/12,27 kg  
 + 0,72 kg/100mm SL

### Design Data

Pressure proc .320/1/2/3: up to 40,0 MPa  
 Temperature media  
 Reference vessel compl. 1.4571: -200 ... +400 °C  
 flanges 1.0460: -10 ... +400 °C  
 Below -10 °C Indicating scale 710.AVG2  
 below -20 °C add frost protection with 710.ISOL  
 In both cases preparation for insulation included

### Certificates

Pressure equipment directive  
 (PED) 97/23/EG  
 EC-Type Examination Certificate: TÜV 03 ATEX 2190  
 Zone 0

Subject to alterations

Ordering no.

7 1 0 . 3 2 X . 0 - X X X - X X X X

Version	Flange-piece, tube as float basket	0
	Flange-piece, wire as float basket	1
	direct, tube as float basket	2
	direct, wire as float basket	3
Density	z.B. 054=0,54 g/cm <sup>3</sup>	

Sight length  
SL

### PHÖNiX

Messtechnik GmbH  
 Salzschlirfer Straße 13  
 D-60386 Frankfurt/M.  
 Tel. +49/69/41 67 42 -20  
 Fax +49/69/41 67 42 - 29  
 sales@phoenix-mt.com  
 www.phoenix-mt.com

# PHÖNiX