

Magnetic level gauge, PN 16/CL150

Magnetic indicating bar scale with fine resolution, indirect level indication
 Indicating elements permanent magnetic with stop pin
 Fully closed housing with gapless weldings
 Float magnet field totally circular with strong far field
 Float defect control with indication in lower display end

Product group **710**

Type **098.0**

Sheet: 1/2

Revision: 7

Date:

08/06

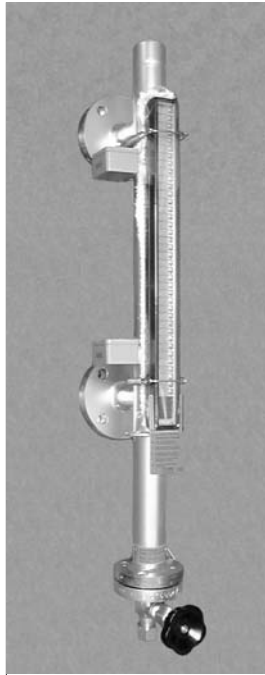

Type 710.098.0 equipped with Magnetic switches MIN and MAX, vent plug, drain valve and indicating scale 710.AVG3.

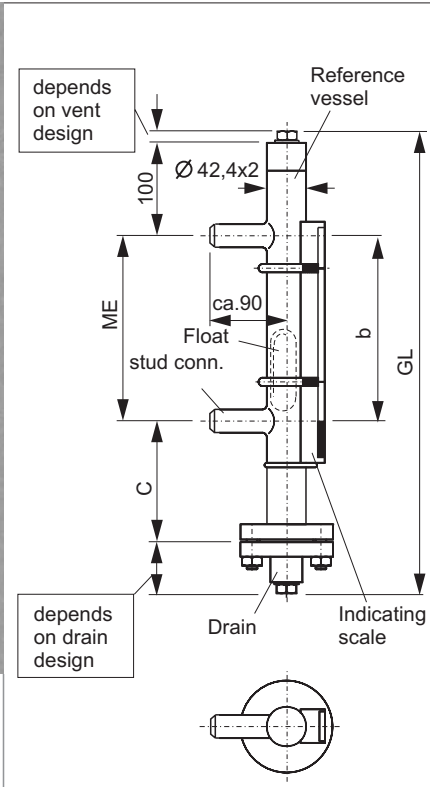

Field of Application

The magnetic level gauge is for indicating the level height of liquids in any vessel via bypass. Simultaneously you can use level switches (s. 740.XXXX) or level sensors (s. 745.XXXX) mounted onto the reference vessel tube to signal level limits or measure the level height by remote means.

General Data

Density: from 0,70 g/cm³
 Precision for Interface or density: from ±0,01 g/cm³
 Measuring range (=ME): single piece up to 5000 mm, above split construction, from 3000 mm holding bracket each 1500 mm
 Measuring error: ±10 mm
 Viscosity: max 1000 mPas
 Display type: 710.AVG3
 Connection: weld end (Standard), Flanges DIN and ANSI
 Drain/vent: Cap (Standard), plug 1/2" NPT, as option 3/4" NPT, G1/2A, G3/4A
 Valve DN6, optional DN8, Flange stud DIN and ANSI and acc. to customer spec.
 Material tube, stud, 1.4571 (Standard), ANSI-coded
 flanges, fixtures: Titanium, Hastelloy, etc.,
 float: 1.4571
 Weight: Basic 7 kg + 0,33 kg/100mm ME

Derating-Diagram

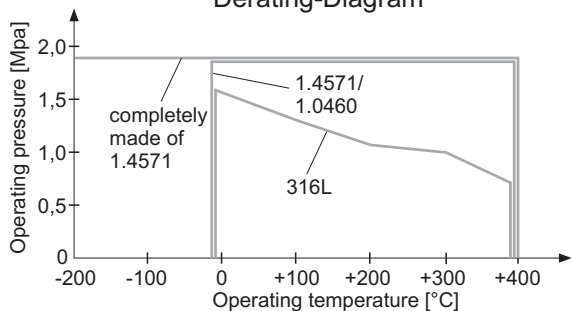

Design Data

Operating pressure: up to 1,9 MPa/150 lbs (see Derating-Diagram)
 Temperature Media
 Reference vessel cpl. 1.4571: -200 ... +400 °C
 flanges 1.0460: -10 ... +400 °C (see Derating-Diagram)
 Below -10 °C Indicating scale .AVG2 and below -20 °C add frost protection with 710.ISOL
 In both cases preparation for insulation included.

Certificates

Pressure Vessel Directive (PED) 97/23/EG
 EC-Type Examination Certificate: TÜV 03 ATEX 2190
 Zone 0
 Subject to alterations

Ordering no.

710.098.0 - XXX - XXXX - XXXXXXXX

Density, e.g.
054=0,54 g/cm³

Center to center ME
in mm

Connections etc.
see sheet
710.VAR

PHÖNIX

Messtechnik GmbH
 Salzschlirfer Straße 13
 D-60386 Frankfurt/M.
 Tel. +49/69/41 67 42 -20
 Fax +49/69/41 67 42 -29
 sales@phoenix-mt.com
 www.phoenix-mt.com

PHÖNIX

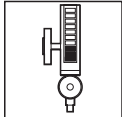

Details

Float, Vent, Drain and Connection

Product group **710**

Type **098.0**

Sheet: 2/2

Revision: 7

Date:

08/06

Float material 1.4571, Ø32, PN16

Density range [g/cm ³]	Measure C [mm]	Total length L [mm]	Weight [g]	Part no.
1,21 ... 1,67	139	125	87	BG1000984167
1,03 ... 1,21	164	150	97	BG1000984121
0,90 ... 1,03	194	180	106	BG1000984103
0,81 ... 0,90	224	210	117	BG1000984090
0,75 ... 0,81	259	245	130	BG1000984081
0,70 ... 0,75	299	285	144	BG1000984075
Interface float (individually designed ±0.01 g/cm ³)				BG1001044TRX

Density range corresponds to measuring error ±10 mm

Design Data

Operating pressure:

to 1,9 MPa/150 lbs
(see derating diagram)
operating pressure x 1,3
-200 ... +400 °C
(see derating diagram)

Test pressure:

Operating temperature:

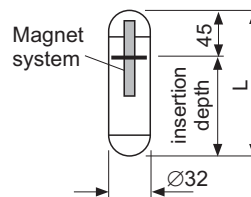

Vent

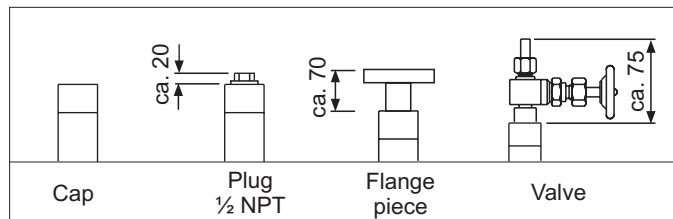

Drain

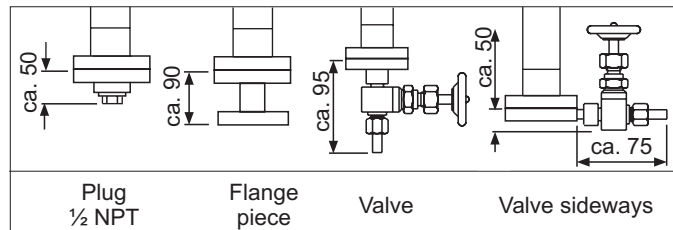

Connections

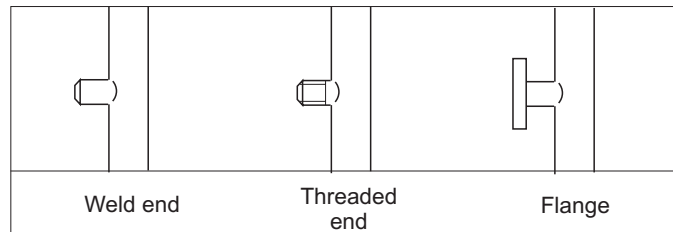

Subject to alterations

Ordering no.

Accessories:

Device	Product group
Magnetic switch	740.XXXX
Level sensor	745.XXXX
Indicating scale	710.AVGX
Frost protection	710.PLEXI
Heating	710.HEAT

Spare parts:

Designation	Part no.
Float	s. Float table above
Indicating scale	BG10.AVGX
Sealing	04750395XXX
Fixing springs	3813000672
Align magnet	BG10XXXXMAKU

There may be any other customer specified connections, materials and special floats.

PHÖNIX

Messtechnik GmbH
Salzschlirfer Straße 13
D-60386 Frankfurt/M.
Tel. +49/69/41 67 42 -20
Fax +49/69/41 67 42 - 29
sales@phoenix-mt.com
www.phoenix-mt.com

PHÖNIX