

www.phoenix-mt.com  
PHÖNiX Messtechnik GmbH

# PHÖNiX

## Sight glass level gauge CL600 bis 1500

"Cold" High pressure  
Reflex, Transparent  
Connection side-side fixed  
Connection gauge valve to gauge chamber: flange  
Handwheel

Product group **700**

Type **25**

Sheet: 35

Revision: 0

Date:

02/05

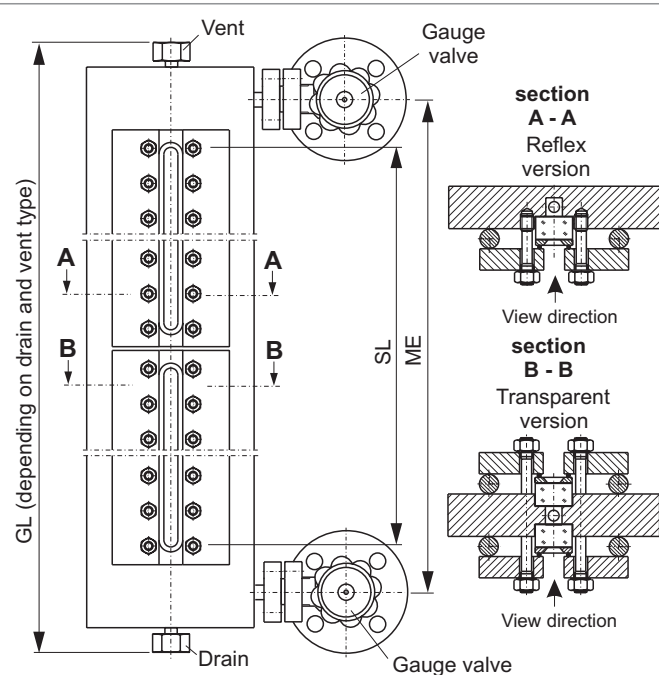

### Field of Application

Direct reading liquid level indicator for general applications up to CL1500 (depends on glass type). Increased safety with ball check valves.

### General Data

Visible length SL:  $\leq$ ME  
Body: 140x40 (Reflex), 200x40 (Transparent)  
Connection gauge valve - body: flange  
Gauge valve types: see data sheet 760.24/25  
Actuation: hand wheel  
Material glass plates acc. to DIN 7081: Borosilicate  
Material media wetted parts: CS, SS  
Depending on delivery situation material can vary.  
Types with special materials e. g. Hastelloy, Monel etc. are available.  
Weight  
- basic weight (glass type 4-11)  
reflex / transparent: 21,0-27,0/24,0-32 kg  
- per segment (glass type 4-11)  
reflex / transparent: 7,9-15,6/10,4-19,8 kg  
Depending on execution weight can vary.

### Design Data

Design pressure/-temperature: see derating  
140x40: see data sheet BG00RE  
200x40: see data sheet BG00RF

### Further Data

Connection gauge valve - body: see 700.VAR  
Process connection: see 700.VAR  
Vent: see 700.VAR  
Drain: see 700.VAR

### Accessories

Glass protection etc.: see accessories  
Frosts protection: see accessories  
Illumination: see accessories  
Scale: see accessories  
Heating: see accessories

CS (= carbon steel) and SS (= stainless steel type 316SS) are materials suitable for Pressure Vessels according to EN or ASME.

Subject to alterations

### Orientation of gauge valve and operation

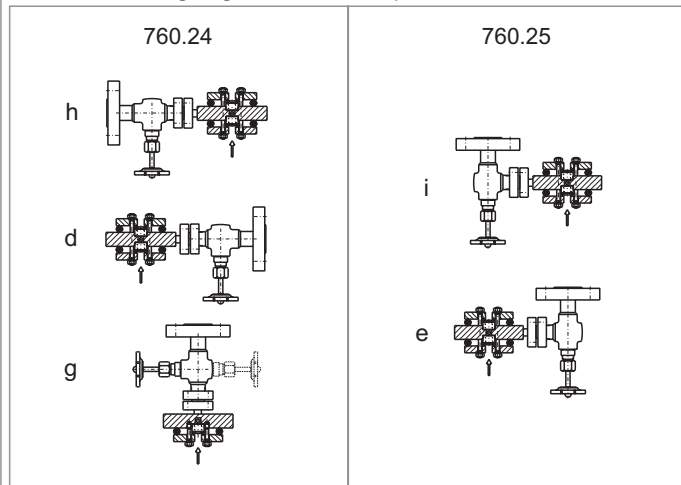

### Ordering no.

7 0 0 2 5 X X X X X X X X X X - X X - X X X X X X X X X X - X X X X X		see 700.VAR	ME [mm]
bridging	without	0	results from ME
	with	1	
glass window	Reflex (DIN 7081)	1	nos of segments
	Transparent (DIN 7081)	2	
gauge valve	760.24	2	DIN-bolts, -nuts
	760.25	2	A ANSI-bolts, -nuts
		5	E 140x40 (Reflex) F 200x40 (Transparent)
			see data sheet 760.50/51/52
			DIN/ASME
			gauge body
			orientation
			gauge valve

### PHÖNiX

Messtechnik GmbH  
Salzschlirfer Straße 13  
D-60386 Frankfurt/M.  
Tel. +49/69/41 67 42 - 20  
Fax +49/69/41 67 42 - 29  
sales@phoenix-mt.com  
www.phoenix-mt.com

# PHÖNiX