

# Sight Flow Indicators (straight line) with Spinner

with **pipe - thread** connection **BSP (G)** or **NPT**



**Cast Iron** GG 25 ( EN-GJL-250 ) max. 16 bar  
**Cast Steel** GS-C 25 ( 1.0619 / GP240GH )  
**Stainless Steel** WN 1.4408

**Bauform 881-RK**  
**Bauform 881-RP**

## Application:

The flow indicators are used for optical control of fluids and gases, for horizontal and vertical pipe-lines.

## Installation:

Optional. Take care of flow direction

## Operating conditions:

Working pressure: max. 16 / 25 / 40 bar  
 Working temperature: max. 120°C or 260°C

## Certificate: (Option)

Acc. to EN 10204-2.2 or 3.1

## Options:

- Flap
- Sight glass light - fittings

## Materials:

Body	GG 25	GS-C 25	1.4408
Covers	GG 25	GS-C 25	1.4408 / 1.4301
Screws	4.6 / 5.6 gal.		A4-70
Glasses	Borosilicate glass DIN 7080 Soda lime glass DIN 8902 ( 150°C )		
Gaskets	Graphite, (or other materials)		
Spinner	Plastic up to 120°C; <b>Bauform 881-RK</b> PTFE up to 260°C; <b>Bauform 881-RP</b>		

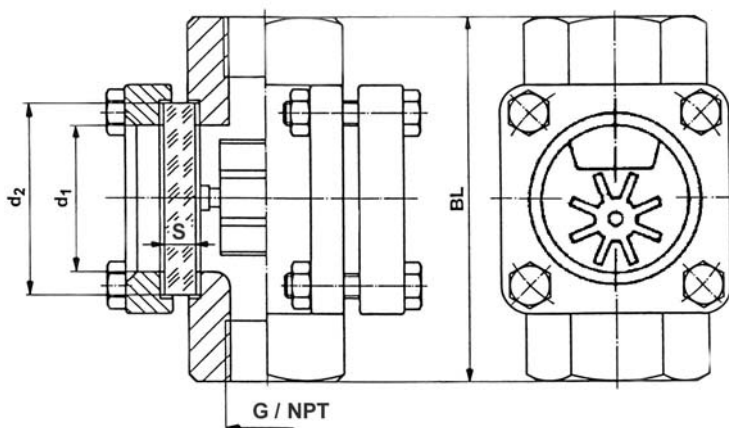

## Ordering example:

Sight Flow Indicators Bauform 881-RP  
 GS-C 25, Borosilicate glass DIN 7080-16 bar  
 Rotor PTFE; G 3/4"



## Dimensions:

BSP (G) or NPT	BL	d <sub>1</sub>	Glass plate			
			d <sub>2</sub>	S		
				16	25	40 bar
1/4" 3/8" 1/2"	100	32	45	10	10	10
3/4" 1"	120	48	63	10	12	15
1 1/4"	160	65	80	12	15	20
1 1/2"	160	65	80	12	15	20
2"	230 180 (GG)	80	100	15	20	25

NPT-thread **only** in GS-C 25 or 1.4408

Modification reserved



AVEMAR cz s.r.o., Lihovarská 10, 716 03 Ostrava - Radvanice  
 Tel.: +420 596 232 996, 596 232 997, Fax: +420 596 232 998  
 E-mail: avemar@avemar.cz, web: www.avemar.cz