

Sight Glass Fittings Rectangular

to be welded directly to tank



Bauform 220

Application:

To show surface of a liquid, for insertion into attachment to tanks, bessels and silos.

Operating conditions:

Temperature : 243°C
Pressure: 16 bar

Materials:

Welding pad:	WN 1.4571	WN 1.4571	RSt 37-2
Cover:	WN 1.4571	RSt 37-2	RSt 37-2
Screws DIN 912:	A4-70	8.8 vz	8.8 vz
Sight glass:	Borosilicate glass DIN 7081, reflex		
Gaskets:	Asbestos free (other materials are available)		

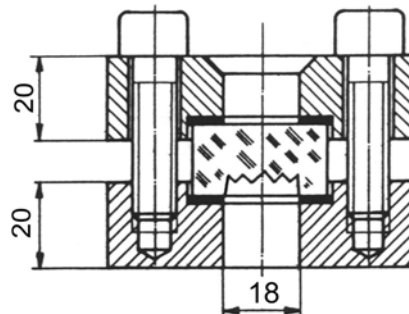

Spezial designs:

are available on request

Mounting instruction:

After welding please examine if sealing area is plane. Otherwise re-machining is necessary.

Example for an order:

Sight Glass Fitting Rectangular Bauform 220
Welding pad WN 1.4571
Cover RSt 37-2
370 x 70 mm

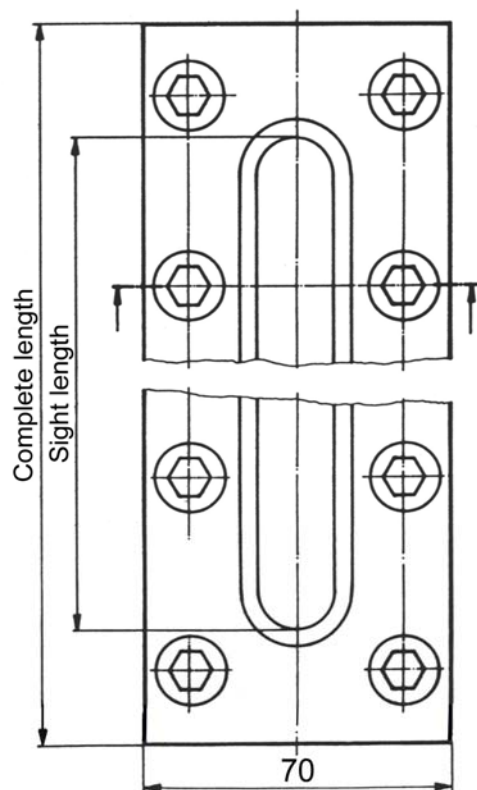
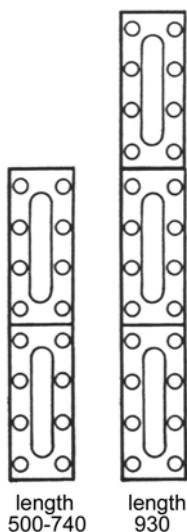
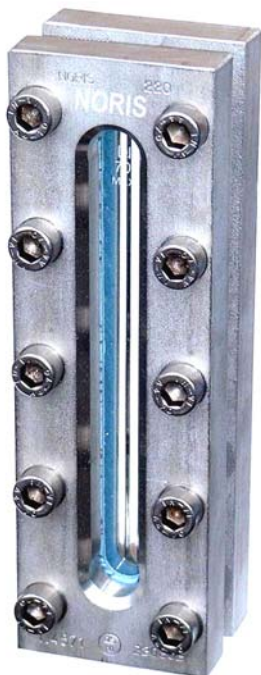

Dimensions:

Complete length	170	220	250	310	370	500	620	740	930
Sight length	120	170	200	260	320	450	570	690	880
Sight interrupted						50	50	50	2 x 50
Number of screws	8	10	12	14	16	24	28	32	42

By length 500 to 740mm there are 2 glasses / by length 930mm there are 3 glasses

Modifications reserved



AVEMAR cz s.r.o., Lihovarská 10, 716 03 Ostrava - Radvanice
Tel.: +420 596 232 996, 596 232 997, Fax: +420 596 232 998
E-mail: avemar@avemar.cz, web: www.avemar.cz