

Bicolour level gauge type green-red

glass-mica, sight openings staggered, even number
lateral connection

Application and function

The bicolour level gauge is a direct water level gauge which can be used for steam generators.

In the sight opening, the water space is indicated in green and the steam space in red. The product corresponds to the PED directive 97/23/EEC art. 3 par. 3 SEP (Sound Engineering Practice).

Applied rules are TRD/AD2000 or ASME-Boilers.

Technical basic equipment

- Body material carbon steel according to ASME
- As left sided (mapped) or right sided model
- Sight length see table
- With drain valve and ventilation plug
- Illumination device LED Duo SOL6/8, IP67
- Shutoff valves type A130, A150 and A220
- Drain valve type AV500, AV 520

Available (optional) versions

- Other drain valve
- Low level mark

Technical data

Allowable pressure	PS [bar]	20	32	50	80
Allowable temperature	TS [° C]	215	239	265	296
Shutoff valve	Type	A130		A150	
	Data sheet	D-09-D-16354-0		D-09-D-16355-0	
	Type	A220			
	Data sheet	D-09-D-16356-0			
Drain valve	Type	AV500	AV520		
	Data sheet	D-09-D-16358-0			

Illumination device	Type	LED Duo SOL 8
	Protection	IP67
	Data sheet	D-A1-D-16386-0

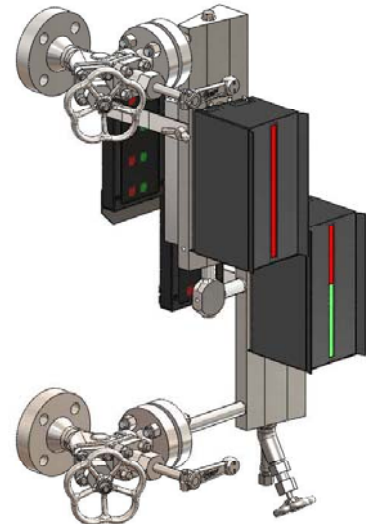

Dimensions and tables

Left sided model

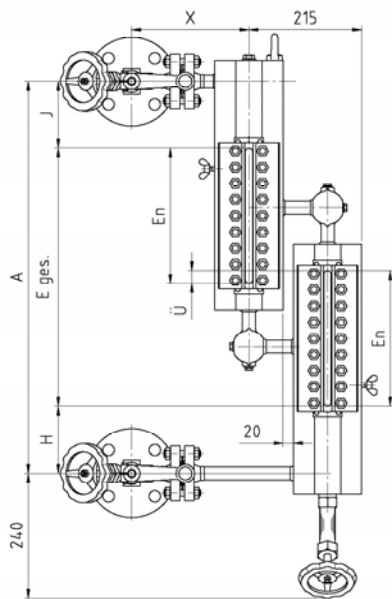

Right sided model

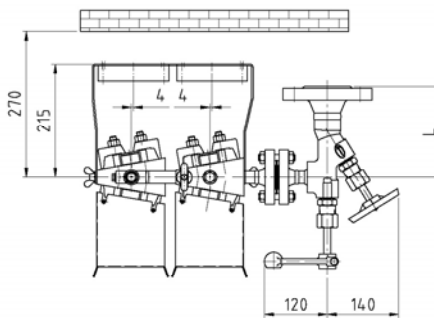
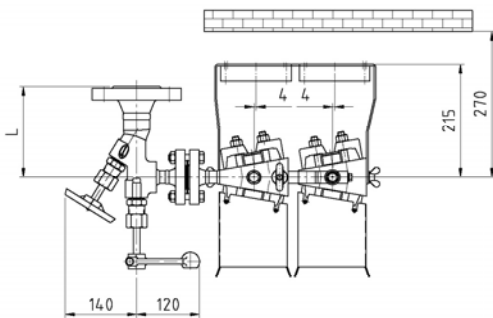
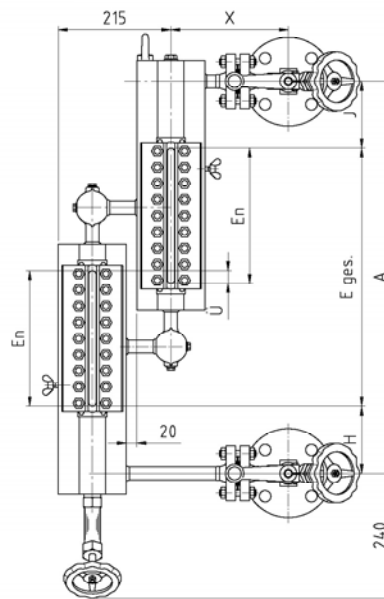

Size		7/nv
Sight length	E	260
Dimension	H/J _{min} [mm]	25
	H/J _{max} [mm]	On request



Information:

Depending on the size and version of the level gauge the customer has to arrange a sufficient brace support (eg. spring suspension etc.).



Dimensions and tables

Allowable pressure PS [bar]	Valve	Flange	L [mm]	Welding end	L [mm]	X [mm]
32	A130	DN20	170	DN20		215
50	A150	DN25	129	DN25		215
80	A150	DN 25	129	DN25		225
80	A220	DN25	160	DN25	160	225

