

## Bicolour level gauge type black-white

one sight opening, lateral connection

### Application and function

The bicolour level gauge black-white is a direct level gauge with illumination and can be used for steam generators. For best results, observe the liquid level standing directly in front of the sight opening. In the sight opening, the height of the liquid level is indicated in black and the steam space in white. The product corresponds to the PED directive 97/23/EEC art. 3 par. 3 SEP (Sound Engineering Practice). Applied rules as per TRD/AD2000 or ASME-Boilers. Possible video transmission of liquid level onto a monitor in the control room.

### Technical basic equipment

- Body material carbon steel
- As left sided (mapped) or right sided model
- Sight length see table
- With drain valve and ventilation plug
- Illumination device IP67
- Shutoff valves type A220 and A240
- Drain valve type AV500, AV 520

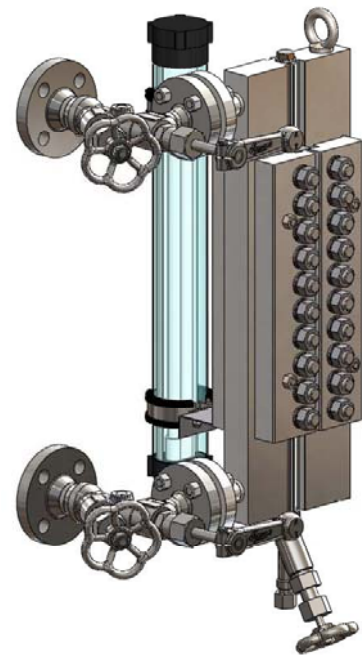

### Available (optional) versions

- Body material according to ASME
- Other drain valve

### Technical data

All. pressure	PS [bar]	32	50	80	100	160	200
All. temp.	TS [° C]	239	265	296	312	348	367
Shutoff valve	Type	A220			A240		
	Data sheet	D-09-D-16356-0			D-09-D-16357-0		
Drain valve	Type	AV500	AV520				
	Data sheet	D-09-D-16358-0					
Illumination	Type	LS-N-02 / -02-S			LS-N-03 / 03-S / -04		
		LS-N-02	LS-N-02-S	LS-N-03	LS-N-03-S	LS-N-04	
		IP67	IP66	IP54		IP66	
		110-230V / 50-60 Hz		230-240V / 50-60 Hz		110-230V	
With integrated ballst unit and plug	With integrated ballast unit and terminal box with main switch	With separate ballast unit and plug	With separate ballast unit and terminal box with main switch	With separate ballst unit and main switch integrated in one terminal box			
D-A1-D-16381-0	D-A1-D-16388-0	D-A1-D-16383-0	D-A1-D-16384-0	D-A1-D-16385-0			



Dimensions and tables

Left sided model

Right sided model

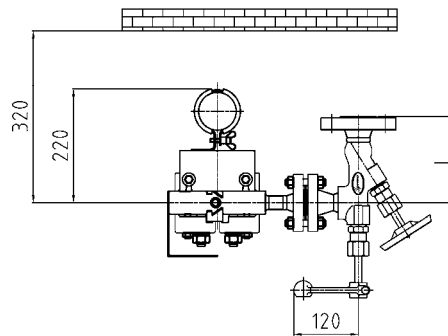
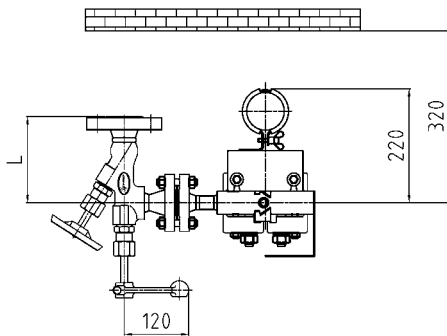
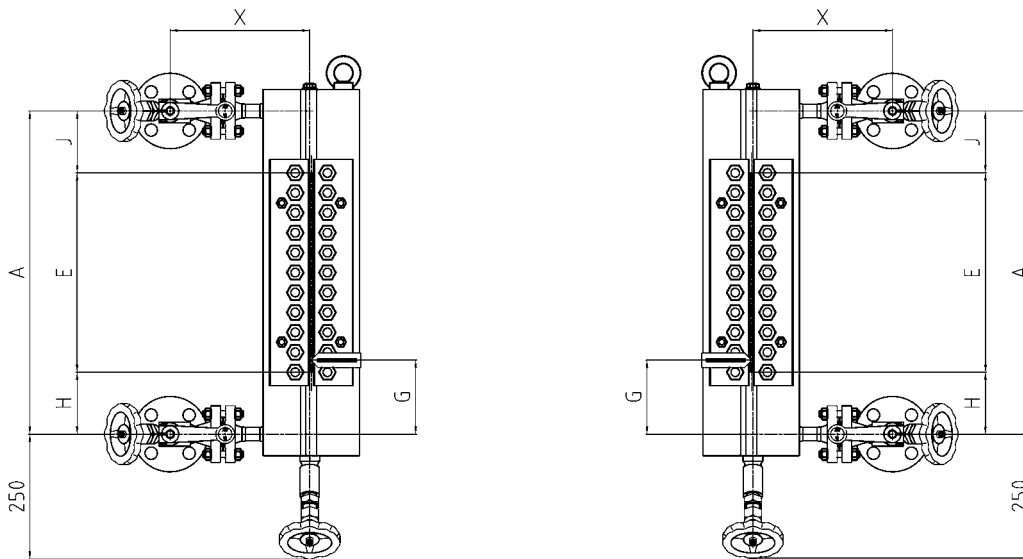

Size		5	6	7	8	9	10	11
Sight length	E	190	220	250	280	310	330	370
Dimension	H/J <sub>min</sub> [mm]	25						
	H/J <sub>max</sub> [mm]	On request						



Information:

Depending on the size and version of the level gauge the customer has to arrange a sufficient brace support (eg. spring suspension etc.).



### Dimensions and tables

Allowable pressure PS [bar]	Valve	Flange	L [mm]	Welding end	L [mm]	X [mm]
32	A220	DN20	170	DN20		240
50	A150	DN25	129	DN25		240
80	A150	DN 25	129	DN25		260
80	A220	DN25	160	DN25	160	260
100	A240	DN25	145	DN25	150	270
160	A240	DN25	155	DN25	150	330
200	A240	DN25	170	DN25	150	330

