

## Globe valve type WA5

### Application and function

Shutoff valve on pipes between steam boiler and water level limiter or controller. The shutoff valve makes easier the separate blowing of connecting pipes (TRD 601, par. 3.2.5 and 3.2.6).

Self-opening shutoff valve with hand lever.

To change position of hand-lever (a), loose screws (b) and turn it in each case at 90° .

To drain the pipe connection , close valve shortly by the Hand-lever (a).

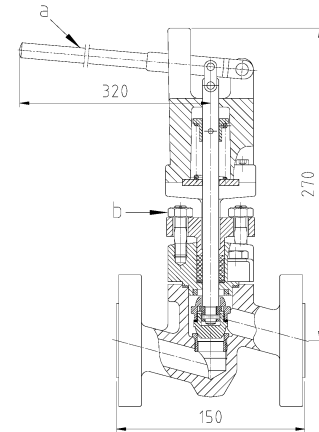

### Technical basic equipment

- Process connection: PS = 32 bar, DN 20/25 DIN 2635-C

### Available (optional) versions

- Other process connection as per DIN or ANSI on request
- Welding end and socket welding on request

### Technical data

Allowable pressure	PS [bar]	32
Allowable temperature	TS [° C]	239

Installation information:

Valve spindle must be in horizontale position

Arrow on valve body (housing) must point towards standpipe