

Globe valve type WA4

with 1 limit switch

Application and function

Shutoff valve on pipes between steam boiler and water level limiter or controller.

The shutoff valve makes easier the separate blowing of connecting pipes (TRD 601, par. 3.2.5 und 3.2.6).

Self-opening shutoff valve with hand lever, possibility to interlock in closed position and limit switch.

To change position of hand-lever (a), loose screws (b) and turn it in each case at 90° .

To drain the pipe connection , close valve shortly by the Hand-lever (a). The safety circuit is not broken. To interlock hand-lever (a) in closed valve position, turn-off handwheel (c).

In this position, the limit switch is actuated and the the safety circuit must be switched-off.

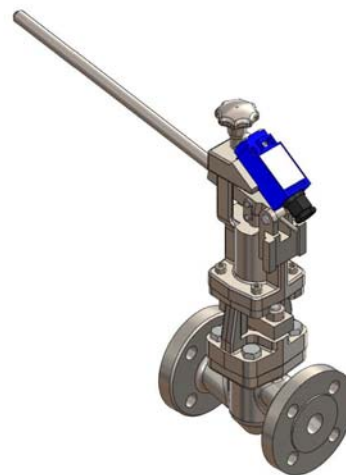

Technical basic equipment

- Process connection: PS = 32 bar, DN 20/25 DIN 2635-C
- Switch: protection IP65 as per IEC/EN 60529
- Contacts: 1 breaker, 1 maker, spring contact
- Switching capacity: continuous current 6A, 235V

Available (optional) versions

- Other process connection as per DIN or ANSI on request
- Welding end and socket welding on request

Technical data

Allowable pressure	PS [bar]	32
Allowable temperature	TS [° C]	239

Installation information:

Valve spindle must be in horizontale position

Arrow on valve body (housing) must point towards standpipe

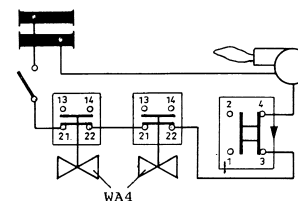
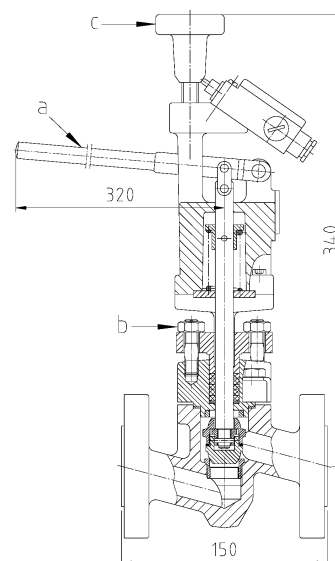

Magnetic switch M130K
in level controller/limiter

