

Float steam trap type SF62

Application and function

Float operated steam trap for drainage and deaeration of steam lines and all kinds of heat exchangers, including those for superheated steam not above 90 K up to saturation vapour temperature, automatic bleeding system, maximum operating safety, no loss of live steam.

Technical basic equipment

- Steam trap with backflow preventer, strainer and deaeration system
- Immediate drainage also by extremely high pressure and volume capacity
- Proof against dirt
- High expectancy and reliability
- Independent from pressure and temperature
- Installation in horizontal or vertical position

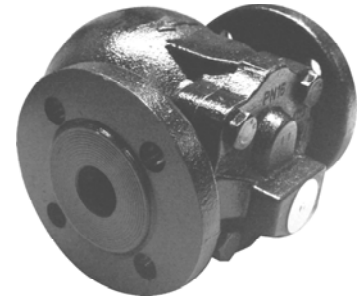

Technical data

Nominal dimension	DN	15/20/25/40/50
Allowable pressure	PS [bar]	4,5 / 10 / 14
All. temperature	TS [° C]	250
Connection	Flanges as per DIN PN 16	
Housing	GGG 40.3	
Inner parts	Stainless steel	

Dimensions

DN	15	20	25	40	50
A	150	150	160	320	320
B	53	53	58	130	138
C	54	54	59	108	122
D	51	55	100	242	250
Weight [kg]	3,2	3,2	4,7	17,6	22



Type	Article no.	DN	PN	PS [bar]
SF62	K-12-30-A1	15	16	4,5
	K-12-30-A2			10
	K-12-30-A3			14
	K-12-30-A4	20	16	4,5
	K-12-30-A6			10
	K-12-30-A6			14
	K-12-30-A7	25	16	4,5
	K-12-30-A8			10
	K-12-30-A9			14
	K-12-30-A10	40	16	4,5
	K-12-30-A11			10
	K-12-30-A12			14
	K-12-30-A13	50	16	4,5
	K-12-30-A14			10
	K-12-30-A15			14

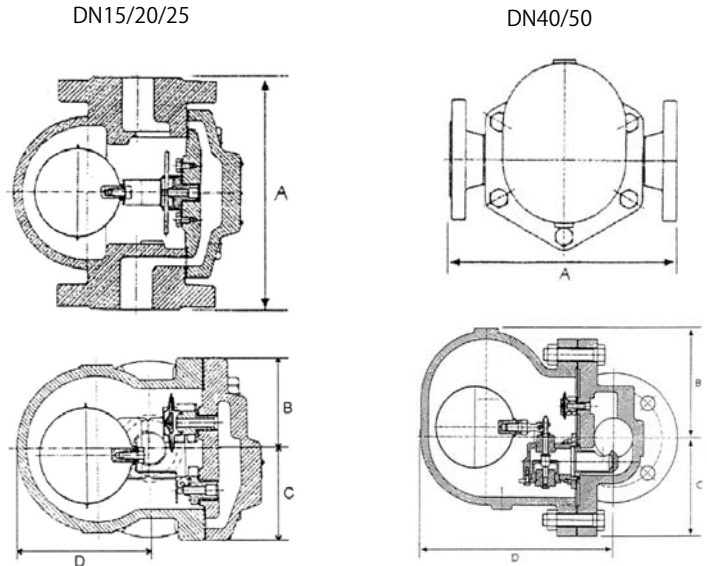

Capacity

	Düse 4,5				Düse 10				Düse 14			
	½", ¾"	1"	1- 1 ½"	2"	½", ¾"	1"	1- 1 ½"	2"	½", ¾"	1"	1- 1 ½"	2"
0,1	115	365	1100	3500	55	187	660	1800	36	68	450	850
0,2	160	425	1450	4800	74	211	925	2600	52	90	625	1250
0,3	180	491	1800	6000	89	249	1150	3100	62	101	750	1450
0,4	190	523	2150	6950	100	280	1300	3500	70	133	850	1700
0,6	225	601	2650	8500	125	314	1625	4250	82	145	1050	2150
0,8	260	689	2950	9600	140	359	1825	4800	93	159	1200	2500
1	275	721	3250	12500	160	391	2125	5400	100	172	1300	2750
2	360	901	4500	15000	200	483	3000	7500	135	224	1800	3600
3	425	1003	5500	17500	240	552	3600	9200	170	272	2250	4500
4,5	500	1225	6700	22500	280	608	4400	11250	190	316	2750	5500
5					300	653	1600	11850	200	323	2900	5850
6					320	699	5100	13100	220	349	3200	6400
8					360	749	6000	15000	250	401	3600	7500
10					400	801	6700	16300	270	451	4000	8400
14									310	503	4700	9500

