

## Float switch type RBA35

### Application and function

The float switch can be used as water level controller or limiter for steam generators as per TRD 401, 402 or 602.

The float switch according to PED directive 97/23/EEC has the CE-mark no. 0035 of the notified body.

Applied rules as per TRD/AD2000 or ASME- Boiler.

### Technical basic equipment

- Material according to DIN or ASME
- Protection as per DIN VDE 0470: IP54
- Process connection: flanges as per DIN or ANSI
- Magnetic switch type M130-KS (D-07-D-16324-0) for 24Vdc
- Cable gland according to DIN EN 50262: M20x1,5
- Drain plug G ½

### Available (optional) versions

- Protection as per DIN VDE 0470: IP65
- Process connection: welding end, Socket Welding
- Level indication (signal lamps), data sheet D-07-D-16323-0
- Ventilation screw
- Drain valve AV 520

### Technical data

EG-component test	CE 0035-BN0106			
Allowable pressure	PS [bar]	100	160	200
Allowable temperature	TS [° C]	312	348	367
Drain valve	Type	AV520		
	Data sheet	D-09-D-16358-1		

Range of adjustment	W [mm]	250	350	450	550	650	750
---------------------	--------	-----	-----	-----	-----	-----	-----



**Dimensions**

- The component mark is only valid if shutoff valves are installed between process connection and boiler studs. A drain valve is also required
- The functional test is made by lowering the water level in the standpipe
- The level switches contains mercury. For this reason, the level switches are not suitable for use on boiler plants, where the steam comes directly in contact to foods or similar, or where the steam is used on air conditioning for humidifying

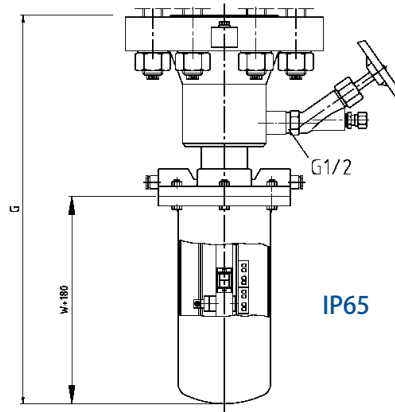
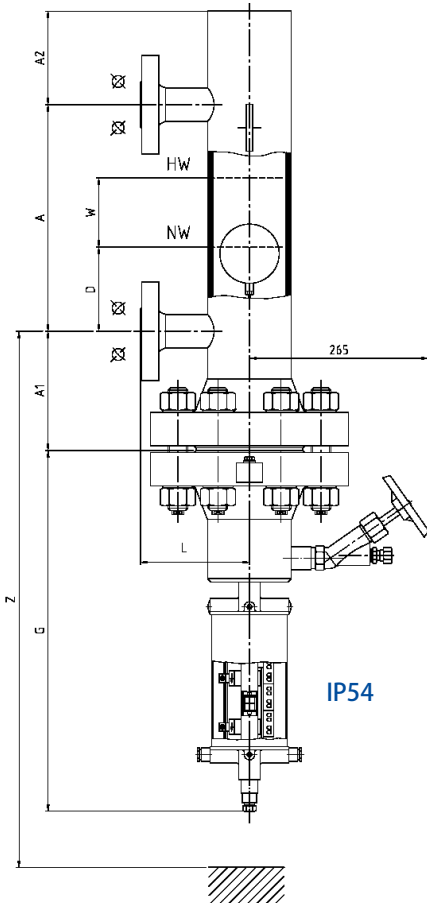

PS	A1	A2	G	Z
100	152	140	W+375	W+D+685
160	177	140	W+390	W+D+755
200	213	140	W+430	W+D+865

**Process connection**

