

## Float switch type RBA24

### Application and function

The float switch can be used as water level controller or limiter for steam generators as per TRD 401, 402 or 602.

The float switch according to PED directive 97/23/EEC has the CE-mark no. 0035 of the notified body.

Applied rules as per TRD/AD2000 or ASME- Boiler.

### Technical basic equipment

- Material according to DIN or ASME
- Protection as per DIN VDE 0470: IP54
- Process connection: flanges as per DIN or ANSI
- Magnetic switch type M130-K (D-07-D-16324-0)
- Cable gland according to DIN EN 50262: M20x1,5
- Drain plug G ½

### Available (optional) versions

- Protection as per DIN VDE 0470: IP65
- Process connection: welding end, Socket Welding
- Level indication (signal lamps), data sheet D-07-D-16323-0
- Ventilation screw
- Drain valve AV 500 or 520

### Technical data

EG-component test	CE 0035-BN0106			
Allowable pressure	PS [bar]	32	50	80
Allowable temperatur	TS [° C]	239	265	296
Drain valve	Type	AV500	AV520	
	Data sheet	D-09-D-16358-1		

Range of adjustment	W [mm]	100	150
---------------------	--------	-----	-----



## Dimensions

- The component mark is only valid if shutoff valves are installed between process connection and boiler studs. A drain valve is also required
- The functional test is made by lowering the water level in the standpipe

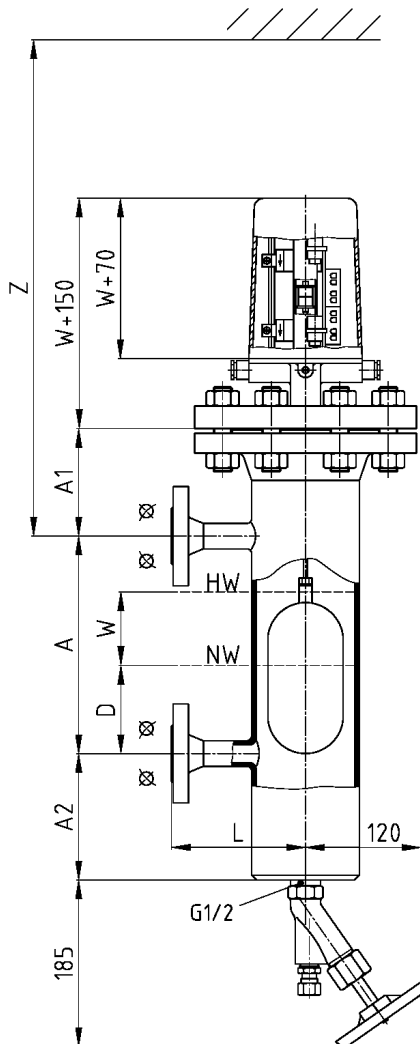

PS	A1	A2	L	Z
32	135	115	140	A-D+550
80	145	155	160	

