

## Magnetic level gauge NA7-45K

Version flange / ventilation plug

### Application and function

The magnetic level gauge in connection with primary element MRK with integrated R/I- converter and a level controller serves as continuous water level regulation. The product corresponding to the PED directive 97/23/EEC has the CE mark no. 0035 of the notified body.

Applied rules as per TRD/AD2000 or ASME Boilers.

### Technical basic equipment

- Standpipe stainless steel
- Process connection carbon steel
- Primary element type MRK (D-06-D-16313-0) with integrated R/I-converter, output 4-20 mA
- Ventilation and drain plug

### Available (optional) versions

- Drain valve AV 500, AV 520 (other drainvalve on request)
- Indicating ledge AL2-G (D-06-D-16311-0) for an indirect reading water level indication. This indication can be used as second water level indicator as per TRD 401
- Additional magnetic switches M510-1-60
- Light band indicator for remote level indication
- Controller
- Motorized control valve

### Technical data

Component mark	TÜV WRS 04-336			
Allowable pressure	PS	[bar]	32	50
Allowable temperature	TS	[° C]	239	265
Drain valve	Type		AV500	AV520
	Data sheet		D-09-D-16358-1	

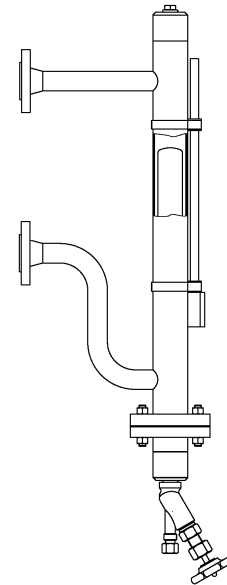

- The indication ledge can be arranged in any position outside the areas of the connection studs
- The component mark is only valid if shutoff valves are installed between process connection and boiler studs. A drain valve is also required
- The functional test is made by lowering the water level in the standpipe

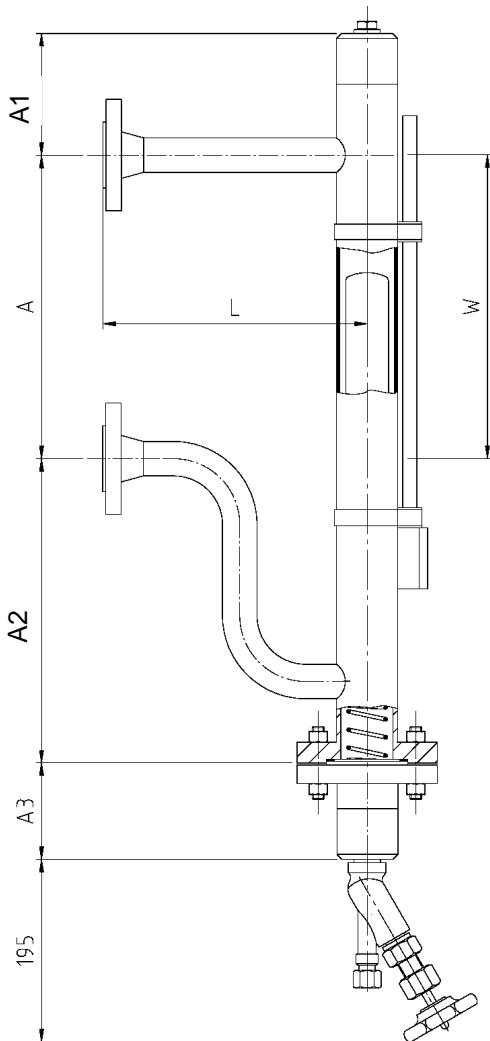

Welding end	Socket welding

PS	A1	A2	A3	L
[bar]	[mm]	[mm]	[mm]	[mm]
32	170	360	100	260
50	170	375	115	275

