

Reflex level gauge LG40

Sight openings superposed

Application and function

The reflex level gauge is a direct level gauge which can be used for steam boilers and containers. In the sight opening, the water level is indicated dark and the steam light.

The product corresponds to the PED directive 97/23/EEC art. 3 par. 3 SEP. (Sound Engineering Practice).

Applied rules as per TRD/AD2000 or ASME Boilers.

Technical basic equipment

- Body material carbon steel
- Sight lengths see table, E > 1700 mm version with intermediate flange see data sheet D-02-D-10000-1
- As left sided (mapped) or right sided model
- With drain valve and ventilation plug
- Shutoff valves type A110, A120 or 210
- Drain valve type AV500

Available (optional) versions

- Body and valves stainless steel
- Other drain valves on request

Technical data

All. pressure	PS	[bar]	32	
All. temperature	TS	[° C]	239	
Drain valve	Type	AV500	Data sheet	D-09-D-16358-0
Shutoff valve	Type	A110	Data sheet	D-09-D-16353-0
	Type	A110		D-09-D-16353-0
	Type	A120		D-09-D-16354-0
	Type	A210		D-09-D-16356-0

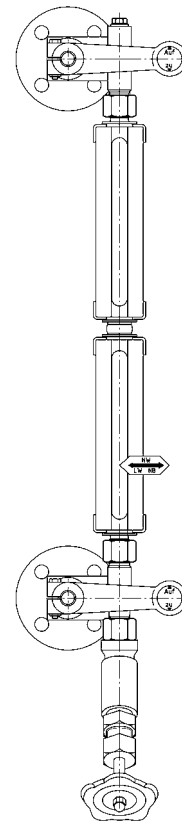

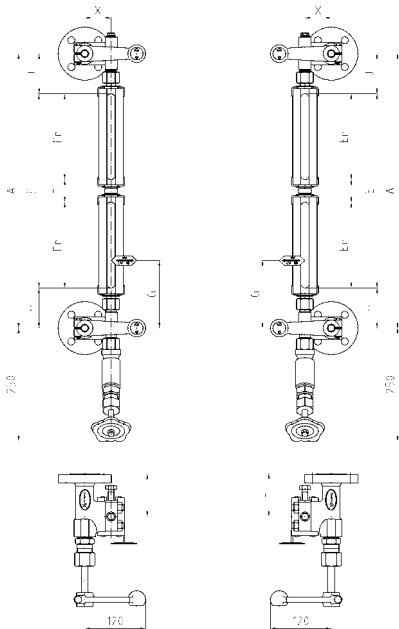
Left sided model Right sided model

One sight opening	Size	5	6	7	8	9	10
	Sight length E_n	200	230	260	300	320	350
Sight openings superposed E	2ü	445	505	565	645	685	745
	3ü	690	780	870	990	1050	1140
	4ü	935	1055	1175	1335	1415	1535
	5ü	1180	1330	1480	1680		
	6ü	1425	1605				
Dimension	H/J _{min} [mm]	55					
	H/J _{max} [mm]	On request					
	T [mm]	45					
	X [mm]	52					

Allowable pressure PS [bar]	Valve	Flange	Welding end	X	L	L1
32	A110			52 mm	85 mm	Handwheel 140 mm
32	A110			52 mm	85 mm	Handlever 155 mm
32	A120	DN20		52 mm	140 mm	175 mm
32	A120	DN25		52 mm	119 mm	175 mm
32	A120		x	52 mm	130 mm	175 mm
32	A210	DN20		52 mm	170 mm	175 mm
32	A210	DN25		52 mm	-	175 mm
32	A210		x	52 mm	160 mm	175 mm

