



ELECTROVANNE 2/2 NF ou NO 2 VOIES A COMMANDE ASSISTEE A PISTON

SOLENOID VALVE 2/2 NC or NO
2 WAYS PRESSURE ASSISTED
WITH PISTON

TYPE 225250 à/to 225255

Construction INOX 316L / AISI 316L



NF/NC

NO/NO

SPECIFICATIONS TECHNIQUES / TECHNICAL SPECIFICATIONS

Fluides admis : air – eau - huile légère
Pression différentielle : 1 à 100 bar maxi
Température du fluide : 100° C maxi
Température ambiante : -10° à +50° C maxi
Viscosité : 40 centistokes maxi
Position de fonctionnement : axe bobine vers le haut
Poids (avec bobine) : 4300 g
Temps d'ouverture ou fermeture: 200 millisecondes maxi

Media : air – water – light oil
Pressure range : 1 to 100 bar max
Media température : 100° C max
Ambient température : -10° to +50° C max
Media viscosity : 40 centistokes max
Mounting : vertical position, coil up
Weight (including coil): 4300 g
Opening or closing time : 200 milliseconds maximum



PRESSION / PRESSURE

	Raccord Ø Port	Ø passage (mm) Ø seat (mm)	Kv L/mn	Pression / Pressure (bar)				Etanchéité seals	Fluid temp. Max °C	Codification pour commande Voir tableau des codifications Code to order See table of references	
				mini	air / air		eau - huile / water - oil				
				CA / AC	CC / DC	CA / AC	CC / DC				
2/2 NF 2/2 NC	1" GAZ 1" BSP	25	152	1	20	20	-	-	NBR EPDM FKM	60 100 100	225250+101001 +voltage+option 225250+301001 +voltage+option 225250+201001 +voltage+option
				1	-	-	20	20	NBR EPDM FKM	60 100 100	225251+101001 +voltage+option 225251+301001 +voltage+option 225251+201001 +voltage+option
				1	50	50	-	-	NBR EPDM FKM	60 100 100	225252+101001 +voltage+option 225252+301001 +voltage+option 225252+201001 +voltage+option
				1	-	-	50	50	NBR EPDM FKM	60 100 100	225253+101001 +voltage+option 225253+301001 +voltage+option 225253+201001 +voltage+option
				1	100	100	-	-	PTFE + NBR PTFE + EPDM PTFE + FKM	60 100 100	225254+811001 +voltage+option 225254+831001 +voltage+option 225254+821001 +voltage+option
				1	-	-	100	100	PTFE + NBR PTFE + EPDM PTFE + FKM	60 100 100	225255+811001 +voltage+option 225255+831001 +voltage+option 225255+821001 +voltage+option
2/2 NO 2/2 NO				1	20	20	-	-	NBR EPDM FKM	60 100 100	225250+101000 +voltage+option 225250+301000 +voltage+option 225250+201000 +voltage+option
				1	-	-	20	20	NBR EPDM FKM	60 100 100	225251+101000 +voltage+option 225251+301000 +voltage+option 225251+201000 +voltage+option
				1	50	50	-	-	NBR EPDM FKM	60 100 100	225252+101000 +voltage+option 225252+301000 +voltage+option 225252+201000 +voltage+option
				1	-	-	50	50	NBR EPDM FKM	60 100 100	225253+101000 +voltage+option 225253+301000 +voltage+option 225253+201000 +voltage+option
				1	100	100	-	-	PTFE + NBR PTFE + EPDM PTFE + FKM	60 100 100	225254+811000 +voltage+option 225254+831000 +voltage+option 225254+821000 +voltage+option
				1	-	-	100	100	PTFE + NBR PTFE + EPDM PTFE + FKM	60 100 100	225255+811000 +voltage+option 225255+831000 +voltage+option 225255+821000 +voltage+option

CARACTERISTIQUES ELECTRIQUES / ELECTRICAL DATA

	Tension / voltage (-10% + 15%) Durée d'enclenchement 100% Continuous duty 100%	Taille Size	Puissance / Power		Classe d'isolation Insulation class	Degré de protection Enclosure	Raccord électrique Electrical connections
			A l'appel Inrush	Au maintien Holding			
~	12-24-48-110-230 (50 ou/or 60 Hz)	40	48 VA	24 VA	F 155°C	IP 65 avec connecteur with connector	3 fiches 3 spades DIN 43650 DIN 40050 VDE 0110
=	12-24-48		14 à/to 20 W				



ELECTROVANNE 2/2 NF ou NO
2 VOIES A COMMANDE ASSISTEE A PISTON
 SOLENOID VALVE 2/2 NC or NO
 2 WAYS PRESSURE ASSISTED WITH PISTON
TYPE 225250 à/to 225255
 Construction INOX 316L / AISI 316L

**ENCOMBREMENT
OVERALL DIMENSIONS**

**2/2 NF
2/2 NC**

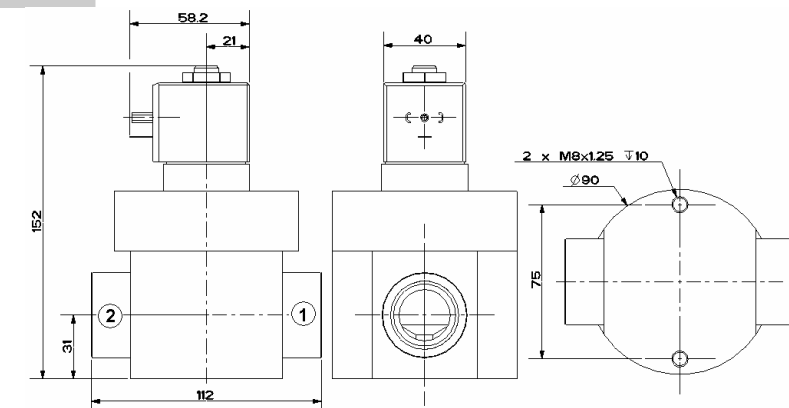

**2/2 NO
2/2 NO**

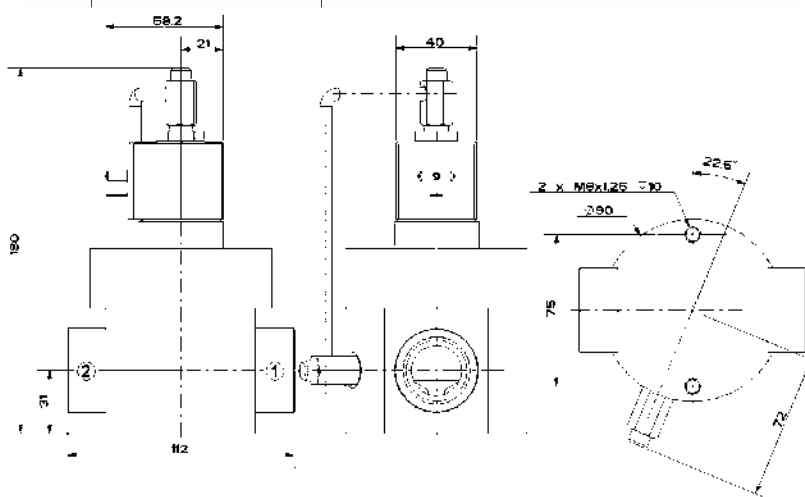

**CONSTRUCTION
CONSTRUCTION**

Corps, tube et pièces internes : acier inoxydable
 Joints et clapets : NBR ou EPDM ou FKM
 Bobine surmoulée : résine

*Body, tube and internal parts : stainless steel
 Seals and gaskets : NBR or EPDM or FKM
 Moulded coil : resin*

**OPTIONS
OPTIONS**

Connecteur PG9 – DIN 43650 A
 Raccord NPT
 Etanchéité PTFE
 Capot anti-déflagrant : mode de protection II 2 G/D
 EEx d IIC T6 suivant ATEX

*Connector PG9 – DIN 43650 A
 NPT thread
 PTFE seals
 Explosion proof enclosure: protection II 2 G/D
 EEx d IIC T6 according to ATEX*

**KITS DE MAINTENANCE
REPAIR KIT**

Désignation <i>designation</i>	Codification pour commande <i>Code to order</i>
Bobine <i>Coil</i>	Voir tableau des codifications bobines <i>See table of coils references</i>
Noyau équipé + joints + piston équipé <i>Complete plunger + O'rings + complete piston</i>	KIT2252 + 50 ou 51 ou 52 ou 53 ou 54 ou 55 + NF ou NO + matière d'étanchéité <i>KIT2252 + 50 or 51 or 452 or 53 or 54 or 55 + NC or NO + seals material</i>