



ELECTROVANNE 2/2 NF ou NO 2 VOIES A COMMANDE DIRECTE SOLENOID VALVE 2/2 NC or NO 2 WAYS DIRECT OPERATED Passage en ligne / In line **TYPE 20012 / 20013**



SPECIFICATIONS TECHNIQUES TECHNICAL SPECIFICATIONS

Fluides admis : air – eau - gaz - huile légère - vide
Pression différentielle : 0 à 12 bar maxi
Température du fluide : 60° C maxi
Température ambiante : -10° à +50° C maxi
Viscosité : 40 centistokes maxi
Position de fonctionnement : indifférente
Poids (avec bobine) : 170 g
Temps d'ouverture ou fermeture: 20 millisecondes maxi

Media: air – water – gas – light oil - vacuum
Pressure range : 0 to 12 bar max
Media temperature : 60° C max
Ambient temperature : -10° to +50° C max
Media viscosity : 40 centistokes max
Mounting : any position
Weight (including coil) : 170 g
Opening or closing time : 20 milliseconds maximum

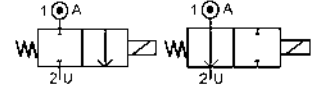

PRESSION PRESSURE

	Ø Raccord Ø Port	Ø passage (mm) Ø seat (mm)	Kv L/mn	mini	Pression / Pressure (bar)				Etanchéité seals	Fluid temp. Max °C	Codification pour commande Voir tableau des codifications Code to order See table of references
					air - gaz / air - gas		eau - huile / water - oil				
					CA / AC	CC / DC	CA / AC	CC / DC			
2/2 NF / 2/2 NC	1/8 GAZ 1/8 BSP	1.2	1	0	12	12	12	12	NBR EPDM FKM	60° 60° 60°	21212+10+0181+voltage+option 21212+30+0181+voltage+option 21212+20+0181+voltage+option
		1.6	1.8	0	12	12	12	12	NBR EPDM FKM	60° 60° 60°	21612+10+0181+voltage+option 21612+30+0181+voltage+option 21612+20+0181+voltage+option
		2	2.3	0	12	12	12	12	NBR EPDM FKM	60° 60° 60°	22012+10+0181+voltage+option 22012+30+0181+voltage+option 22012+20+0181+voltage+option
		2.4	3	0	12	12	12	12	NBR EPDM FKM	60° 60° 60°	22412+10+0181+voltage+option 22412+30+0181+voltage+option 22412+20+0181+voltage+option
		3	4	0	12	5	12	5	NBR EPDM FKM	60° 60° 60°	23012+10+0181+voltage+option 23012+30+0181+voltage+option 23012+20+0181+voltage+option
2/2 NO / 2/2 NO		1.2	1	0	12	12	12	12	NBR EPDM FKM	60° 60° 60°	21213+10+0180+voltage+option 21213+30+0180+voltage+option 21213+20+0180+voltage+option
		1.6	1.8	0	12	12	12	12	NBR EPDM FKM	60° 60° 60°	21613+10+0180+voltage+option 21613+30+0180+voltage+option 21613+20+0180+voltage+option
		2	2.3	0	12	12	12	12	NBR EPDM FKM	60° 60° 60°	22013+10+0180+voltage+option 22013+30+0180+voltage+option 22013+20+0180+voltage+option
		2.4	3	0	9.5	9.5	9.5	9.5	NBR EPDM FKM	60° 60° 60°	22413+10+0180+voltage+option 22413+30+0180+voltage+option 22413+20+0180+voltage+option
		3	4	0	6	6	6	6	NBR EPDM FKM	60° 60° 60°	23013+10+0180+voltage+option 23013+30+0180+voltage+option 23013+20+0180+voltage+option

CARACTERISTIQUES ELECTRIQUES ELECTRICAL DATA

Tension / voltage (-10% + 15%) Durée d'enclenchement 100% Continuous duty 100%	Taille Size	Puissance / Power		Classe d'isolation Insulation class	Degré de protection Enclosure	Raccord électrique Electrical connections
		A l'appel Inrush	Au maintien Holding			
~ 12-24-48-110-230 (50 ou/or 60 Hz)	30	26 VA	14 VA	F 155°C	IP 65 avec connecteur with connector	3 fiches 3 spades DIN 43650 DIN 40050 VDE 0110
= 12-24-48		10 W				



ELECTROVANNE 2/2 NF ou NO
2 VOIES A COMMANDE DIRECTE
SOLENOID VALVE 2/2 NC or NO
2 WAYS DIRECT OPERATED
Passage en ligne / In line
TYPE 20012 / 20013

ENCOMBREMENT
OVERALL DIMENSIONS

TYPE 20012 NF

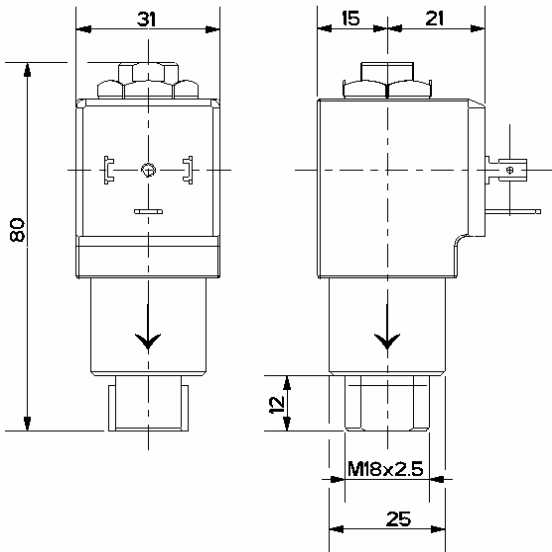

TYPE 20013 NO

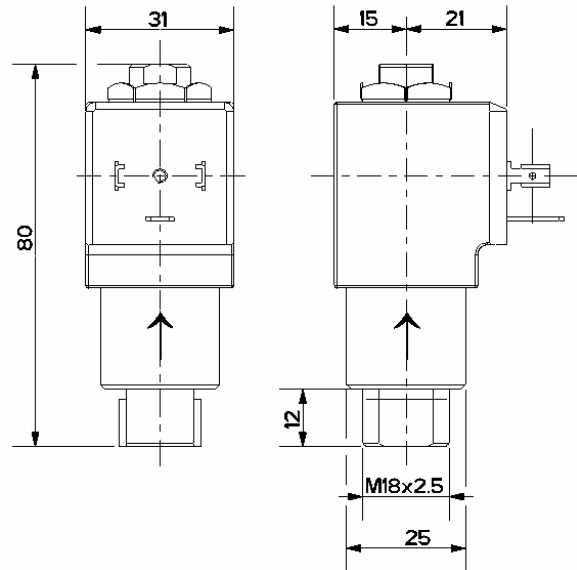

CONSTRUCTION
CONSTRUCTION

Corps : nylon chargé verre
Tube et pièces internes : acier inoxydable
Joints et clapets : NBR ou EPDM ou FKM
Bobine surmoulée : Polyamide

Body : nylon reinforced with glass
Tube and internal parts : stainless steel
Seals and gaskets : NBR or EPDM or FKM
Moulded coil : Polyamide

OPTIONS
OPTIONS

Connecteur PG9 – DIN 43650 A

Connector PG9 – DIN 43650 A

KITS DE MAINTENANCE
REPAIR KIT

Désignation <i>designation</i>	Codification pour commande <i>Code to order</i>
Bobine <i>Coil</i>	Voir tableau des codifications bobines <i>See table of coils references</i>
Noyau équipé + joints <i>Complete plunger + O'rings</i>	KIT20012 ou KIT20013+ matière d'étanchéité <i>KIT20012 or KIT20013+ seals material</i>