

Technical Description

1. Assembly Sketch

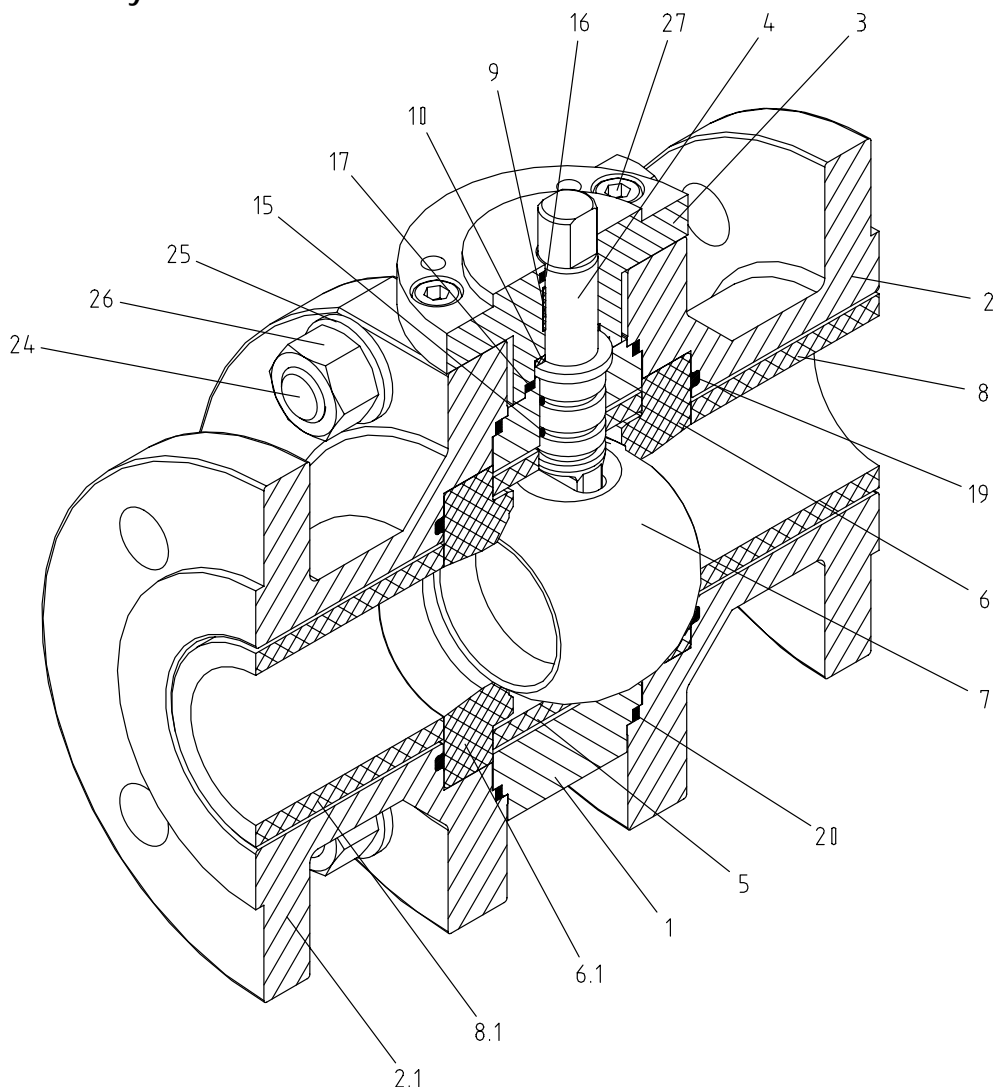

2. Standard Part List

Material indicated is for standard type. See specific appendix for other types.

Item	Part Description	Material
1	Valve body	AISI 316
2	Outlet Flange	AISI 316
2.1	Inlet Flange	AISI 316
3	Bonnet Flange	1.4301
4	Stem / Shaft	1.4462
5	Socket	Al ₂ O ₃
6	Downstream Seat	Al ₂ O ₃
6.1	Upstream Seat	Al ₂ O ₃
7	Ball	ZrO ₂

Item	Part Description	Material
8	Outlet Wear Sleeve	Al ₂ O ₃
8.1	Inlet Wear Sleeve	Al ₂ O ₃
9	Bushing	Klüberplast
10	Spacer	PTFE
15-20	O-Ring	Viton
24	Bolt	A2-70
25	Washer	A2-70
26	Nut	A4
27	Socket screw	A2-70

3 Operation

The *CERAVALVE* type *KST* is a ceramic valve for on / off and control applications in corrosive and abrasive environments that require special stem packing sealing and custom made body material (eg. Titanium, PVDF...).

Applications for this type of valve are high-, as well as very low- temperature and high pressure environments.

The basic principle of this valve is based on the floating ball sealing against the downstream seat using the differential pressure as sealing force. Both seats are fixed (stationary) while the ball has a predetermined "float-space".

The ceramic components are embedded into a metal housing which absorbs the physical torque and vibration resulting from the pipeline.

The quarter turn motion of the ball (0-90) yields in a specific valve opening.

The geometrical shape of the ball allows for different control characteristics in function of process requirements.

The ball valve has a three-part-body design. This allows direct connection to existing pipelines while optimising flow and control characteristics (larger opening angles thanks to a reduced central bore).

Actuator connection is done by yoke and adapter. All kinds of quarter turn pneumatic, hydraulic and electric actuators can be used. Manual operation with hand lever is also available. Standard connection is according to the DIN / ISO 5211, special connections are possible.

4 Flow Characteristics

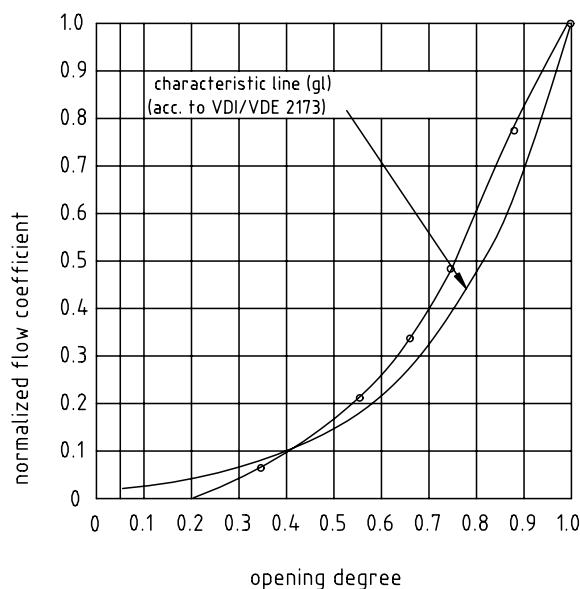
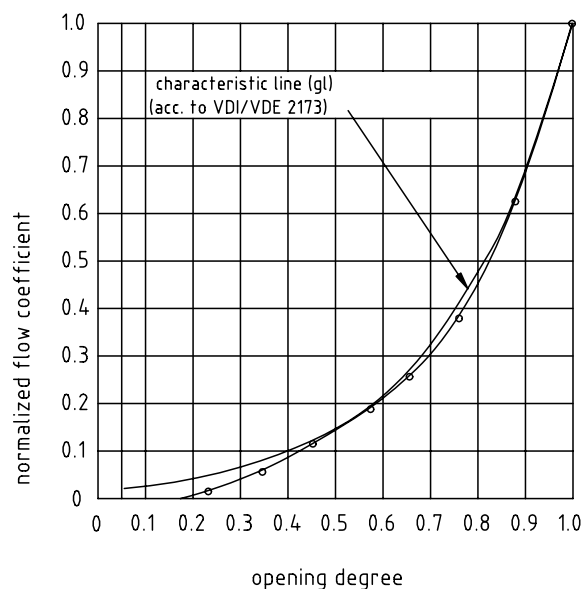

Nominal Diameter : DN 15-200
Ball bore : Triangular
Characteristics : equal percentage

Nominal Diameter : DN 15-200
Ball bore : round
Characteristics : equal perc.