

Pressure & Temperature Switches

The "User Friendly Generation"
General Bulletin

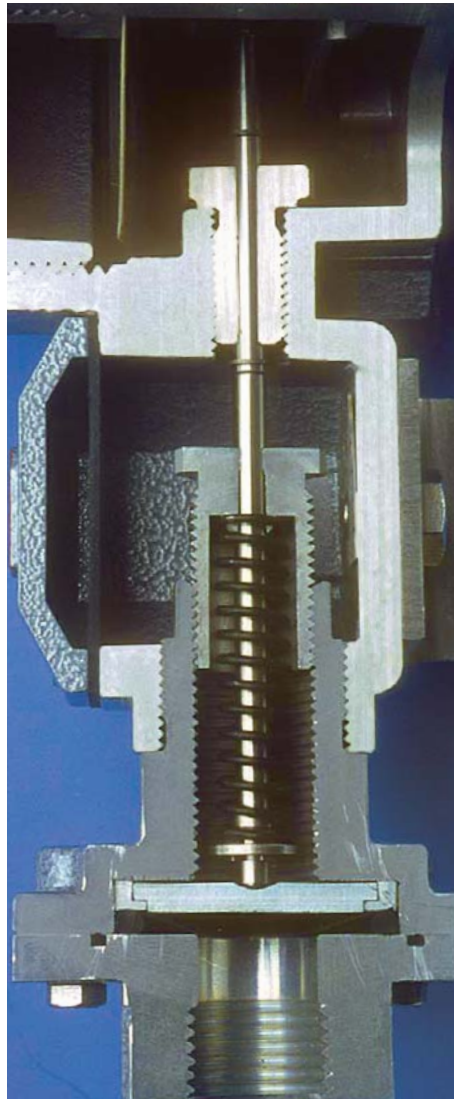

BETA SWITCH PRINCIPLE

Stainless steel screws throughout

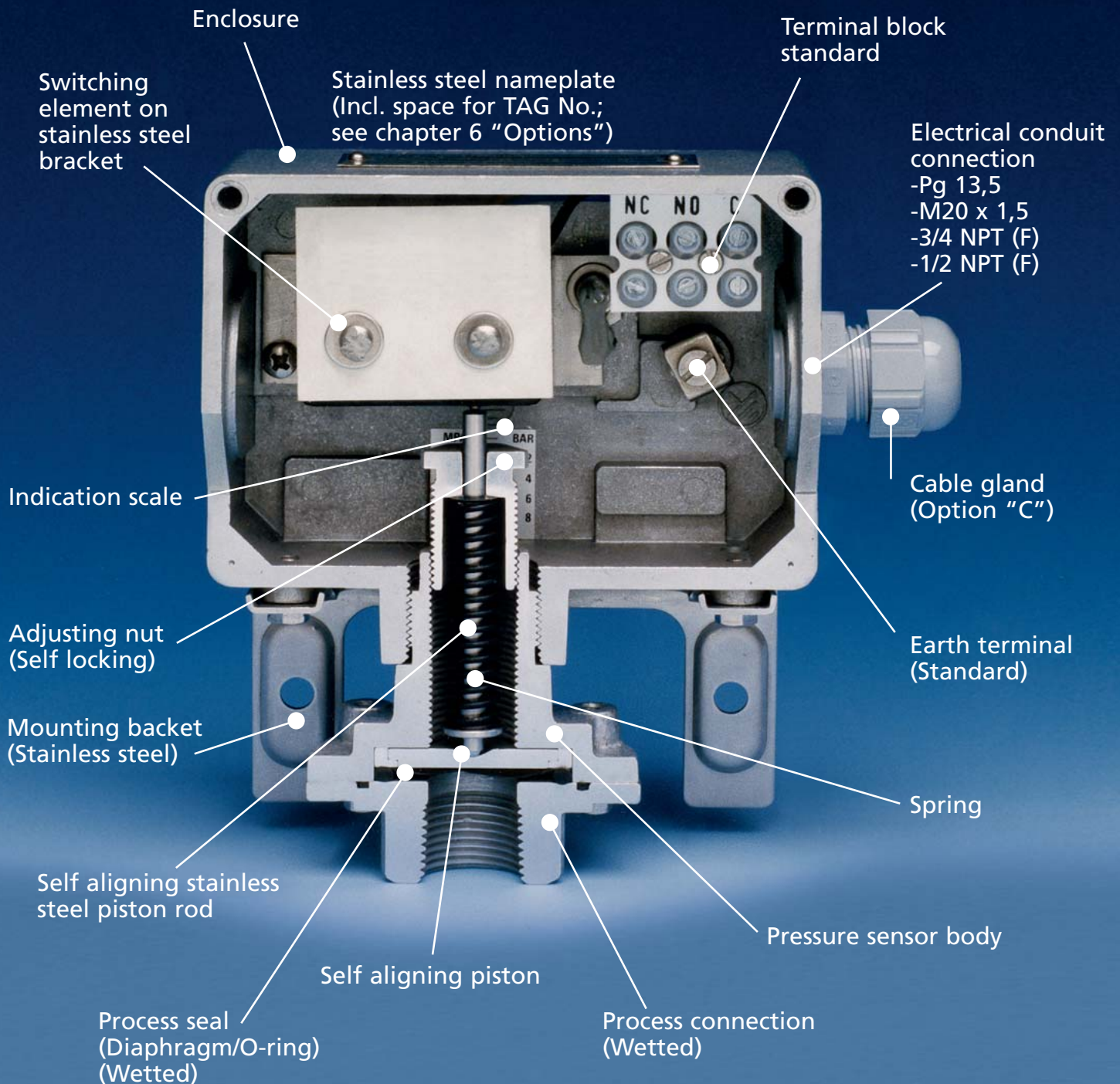

THE “USER FRIENDLY GENERATION”

- The “User Friendly Generation” is no idle boast. BETA can – and always will – supply the best - instrumentation for the given conditions.
- Many years of close attention to our customer’s requirements has resulted in a vast experience of virtually all known switch applications.
- Benefiting from this experience and using our expertise, you will find all of this in our “User Friendly Generation”.

YOUR “SPECIAL” IS PROBABLY BETA’S “STANDARD”

Major users of switches all over the world, all areas of industry, already enjoy the benefits of BETA’s “user friendly” switches. BETA manufactures high quality instruments to meet all of your requirements.

THE BETA PRINCIPLE

A high quality, self-aligning diaphragm/piston sensor is the heart of a BETA switch. The limited piston travel translates pressure at the diaphragm directly to actuation of the microswitch, with no intervening linkages or mechanisms and with full protection against very high overrange pressure.

The piston sensor is isolated from the process fluid by a diaphragm and static O-ring seal, retained by a process connection port. These three are the only process wetted parts and are available in an extensive range of materials.

THE BETA SWITCH HAS “DESIGNED-IN” RELIABILITY.

THE FEATURES

SAFETY

- Safe, secure electrical hookup by clamp terminals.
- Standard earth terminal.
- IP 66 enclosure.
- Solid cover with gasket and captive screws.

RELIABILITY

- Highest Overrange protection.
- Spring loaded piston, excellent resistant against shock and vibration.
- No pipe strains on the instrument to cause shift of setpoint, due to separate flexible stainless steel mounting bracket.

APPROVED BY

ATEX: KEMA CE 0344 and PED: TÜV CERT. CE 0035.
(For more; see also page 16,17 and 18).

QUALITY SGS

SGS certified Quality Assurance according to ISO 9001 - 2000 covers all switch manufacturing, Engineering & Design.

ECONOMY

The wide range of process-wetted materials virtually eliminates the need for costly chemical seals.

SERVICE

The international BETA sales network backs up this high quality product with an equally high quality service.



GUIDE OF HOW TO SELECT YOUR BETA SWITCH

From a simple and logical model code system for easy, accurate product specification, through project coordination, efficient document handling and after sales service BETA aims to make life easier for its valued customers and users.

C1 - P304L - S1N - B1 - K1 - Y - X2

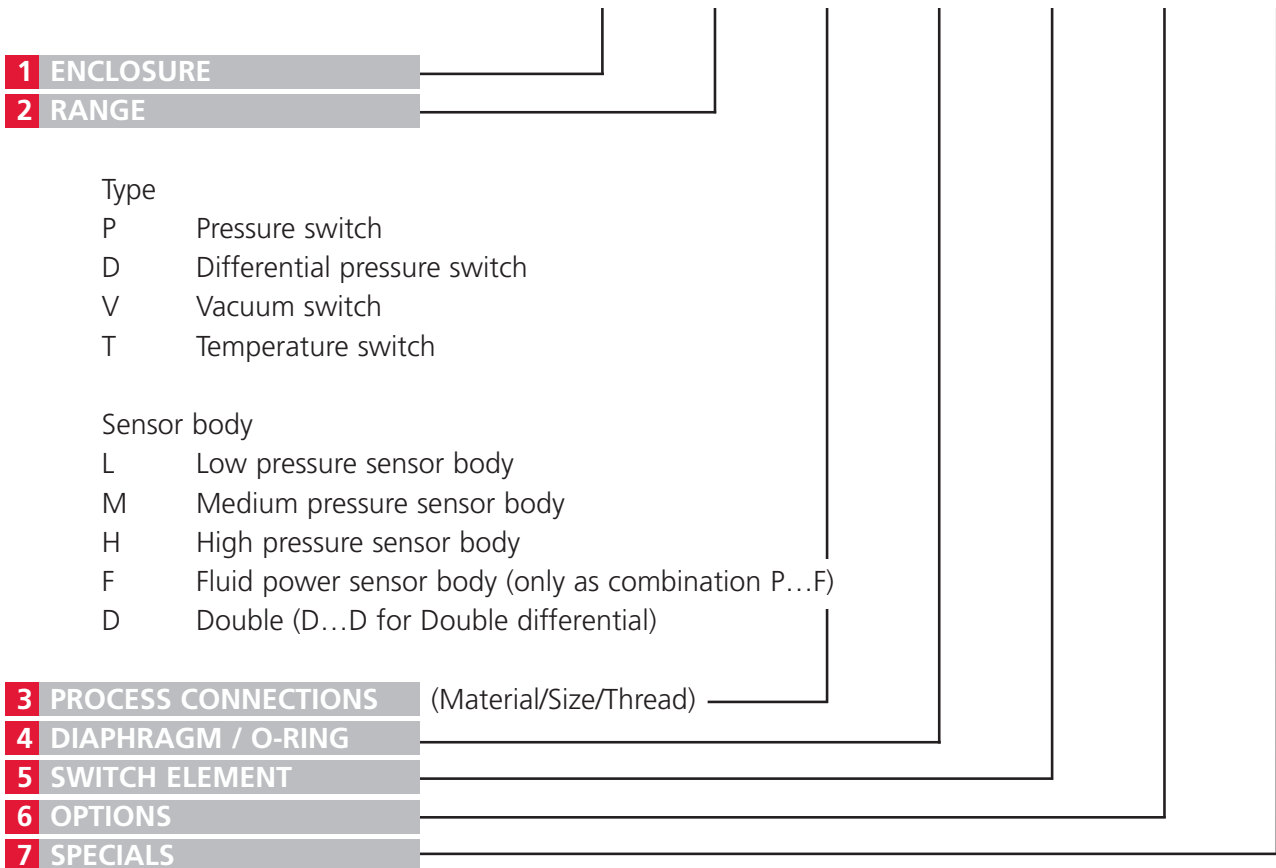

TO SELECT YOUR SWITCH

Follow section **1** through **5** If required: For "Optional" and "Special" accessories Follow section **6** or **7** .

Ambient temperature: Standard: -30 to +80°C
 Ex. proof: -20 to +40°C : M-Serie for T6
 -40 to +40°C : V- and W-Serie for T6
 -40 to +80°C : V- and W-Serie for T5
 -40 to +65°C : Z-Serie for T6
 Ex. i : -30 to +80°C : C-Serie

Repeatability: ± 0.2% of Full Range* (measured at 20°C ambient temperature acc. to ANSI/I.S.A.-S51.1-1979).

Free of charge: BETA will add your tag no. on the nameplate and set the pressure switches at desired setpoint if this is requested on your order.
 (Temperature switches setting against additional charge)

* For standard BETA switch (Switch with "K1" switching element and "B1" diaphragm/O-ring).

PRESSURE SWITCHES

1 ENCLOSURE

C1 - P304L - S1N - B1 - K1 - Y - X2



ENCLOSURE CODE	CLASSIFICATION	ELECTRIAL COND. CONN.	MATERIAL	EARTH TERMINAL	TERM. BLOCK	TYPE OF SENSOR				
						PRESS	FLUID P.	VACUUM	DIFF.	TEMP.
B2	1) Weathertight Miniature (IP65)	Hirschmann Plug conn. DIN 43650-A	Aluminium	Standard (Via plug)	Not applicable	√	√	√	-	√
C1	Weathertight (IP66)	PG 13,5	Aluminium	Standard (Internal)	Standard	√	√	√	√	√
C2		M20 x 1,5								
C3		3/4" NPT (F)								
C4		1/2" NPT (F)								
C8		M20 x 1,5	SS 316 2)							
G3	Weathertight (IP66)	Sealed wire leads	Aluminium	No	Not applicable				√	
M0	Miniature Explosion-proof EEx ed IIC T6 (IP65) 02 ATEX 2189X	Wire leads (0,5m)	SS 316 2)	Standard (Wire lead 0,5m)	Not applicable	√	√	√	√ 3)	√
W3	Explosion-proof EEx d IIC T6 (IP65) 02 ATEX 2186X	3/4" NPT (F)	Aluminium	Standard In- & External	Standard	√	√	√	√	√
V5		M20 x 1,5	Cast Iron 2)			√	√	√	√	√
Z1	Explosion-proof EEx ed IIC T6 (IP65) 02 ATEX 2187X	PG 13,5	Aluminium	Standard In- & External	Standard EEx e	√	√	√	√ 4)	√
Z2		M20 x 1,5								
Z3		3/4" NPT (F)								
Z4		1/2" NPT (F)								
Z8		M20 x 1,5	SS 316 2)							

1) See separate brochure BETAMINI for Ranges, Process Connections etc.
Enclosure "B2" only available with Range codes P...H, P...F and V...H.

2) Includes SS 316 sensor body and adjusting nut.

3) D...L and D...H type only.

4) All differentials except D...D-type.

PRESSURE SWITCHES

2 RANGES for Pressure switches

C1 - **P304L** - S1N - B1 - K1 - Y - X2

"Ranges" given here are valid for setpoints at increasing pressures (vacuum) in barg (mbar). The "Deadband" values are the max. possible values for a standard micro & diaphragm/ O-ring and varies nearly linear with setpoint between indicated limits of range and should be multiplied by deadband multipliers as given in section 4 and 5, where appropriate. (For Fluid Power multiplier acc. to section 5 only). Selection of other than standard micro may influence lower end of range. For deadband calculation in combination with "SR"- and "SP"- micro, Consult Factory.

RANGE CODE	ADJUSTABLE RANGE	MAX. DEADBAND	MAX. OVERRANGE PRESSURE	PROOF PRESSURE
P 301 L ¹⁾	2 - 15 mbar	1,1 - 1,9 mbar	10 bar	15 bar
P 302 L ¹⁾	10 - 100 mbar	2,5 - 3,5 mbar	30 bar	35 bar
P 304 L	20 - 240 mbar	6 - 9 mbar		
P 306 L	20 - 560 mbar	6 - 12 mbar		
P 308 L	25 - 1300 mbar	7 - 15 mbar	125 bar	140 bar
P 402 M	100 - 400 mbar	15 - 20 mbar		
P 404 M	100 - 950 mbar	15 - 30 mbar		
P 406 M	120 - 2300 mbar	16 - 50 mbar		
P 408 M	150 - 5400 mbar	16 - 90 mbar	200 bar	600 bar
P 502 H	0,3- 1,6 bar	65 - 95 mbar		
P 504 H	0,4- 3,5 bar	65 - 160 mbar		
P 506 H	0,5- 9,0 bar	65 - 330 mbar		
P 508 H	0,7- 21,5 bar	70 - 810 mbar		
P 706 H	2,5- 32 bar	0,3 - 1,65 bar	400 bar	
P 708 H	3,0- 76 bar	0,3 - 3,75 bar		
P 808 H	4,0- 170 bar	0,8 - 9,5 bar		
P 908 H	10 - 300 bar	2,0 - 19,5 bar	400 bar	
P 909 H	10 - 350 bar	2,0 - 25 bar		

¹⁾ Only available with L1 – microswitch element. (K1/G1 possible consult factory). Not available on M- and Z-series switches.

RANGES for Fluid power switches ¹⁾

RANGE CODE	ADJUSTABLE RANGE	MAX. DEADBAND	MAX. OVERRANGE PRESSURE	PROOF PRESSURE
P 904 F	12 - 55 bar	3,5 - 6,0 bar	650 bar	700 bar
P 906 F	16 - 130 bar	4,0 - 8,5 bar		
P 908 F	20 - 300 bar	6 - 12 bar		
P 918 F	30 - 540 bar	15 - 31 bar		

¹⁾ Fluid Power switches are to be used on clean, lubricating fluids only.

RANGES for Vacuum switches

RANGE CODE	ADJUSTABLE RANGE ¹⁾ (INCR. VAC. TO PRESS.)	MAX. DEADBAND (VAC. / PRESS.)	MAX. VACUUM	MAX. OVERRANGE PRESSURE	PROOF PRESSURE
V 304 L	- 60/0/ + 150 mbar	4/ 4/ 6,5 mbar	- 500 mbar	+ 30 bar	+ 35 bar
V 404 M	- 400/0/ + 400 mbar	16/16/25 mbar	- 1 bar	+ 125 bar	+ 140 bar
V 406 M	- 980/0/ +1000 mbar	30/30/40 mbar	- 1 bar	+ 125 bar	+ 140 bar
V 506 H	- 1/0/ + 6 bar	80/80/25 mbar	- 1 bar	+ 200 bar	+ 600 bar

¹⁾ For setpoint around zero bar gauge, consult factory. (Note: Setpoint stability around zero bar cannot be guaranteed)

PRESSURE SWITCHES

2 RANGES for Differential switches

C1 - **D352H** - S1N - P1 - K1 - Y - X2

RANGE CODE	ADJUSTABLE DIFF. RANGE ¹⁾	TYPICAL DEADBAND ¹⁾	MAX. STATIC PRESSURE	MAX. OVERRANGE PRESSURE	PROOF PRESSURE
P301L - ... - D ⁵⁾	2 - 15 mbar ²⁾	1,1 - 1,9 mbar	10 bar	10 bar ³⁾	15 bar
D 302 L	12 - 75 mbar ²⁾	7 mbar	30 bar	30 bar ³⁾	35 bar
D 304 L	22 - 180 mbar	8 mbar			
D 306 L	25 - 450 mbar	11 mbar			
D 309 L	35 - 1250 mbar	15 mbar			
D 402 M	0,3 - 1,0 bar	0,15 bar	10 bar	140 bar ⁴⁾	140 bar
D 404 M	0,5 - 2,5 bar	0,2 bar	50 bar		
D 406 M	1,0 - 6,0 bar	0,2 bar			
D 408 M	1,0 - 14,5 bar	0,2 bar	100 bar		
D 506 M	5 - 20 bar	0,8 bar			
D 508 M	10 - 50 bar	0,8 bar			
D 608 M	10 - 70 bar	1,5 bar	140 bar		
D 352 H	80 - 160 mbar	25 mbar	200 bar	200 bar ⁴⁾	200 bar
D 354 H	100 - 500 mbar	35 mbar			
D 356 H	120 - 1450 mbar	50 mbar			
D 359 H	150 - 3450 mbar	75 mbar			

RANGES for Bi-Directional Differential switches

D 356 D	100 - 1500 bar	35 - 11 mbar	200 bar	200 bar ⁴⁾	200 bar
D 358 D	100 - 3500 bar	45 - 115 mbar			

NOTES:

- 1) Ranges and deadbands are given at 50% of Max. Static pressure. All differential pressure sensors are sensitive to static pressure, both for setpoint and deadband.
- 2) Range only with L1 micro switch.
- 3) P301L-D and D...L can withstand a differential pressure P-low max. 1 bar above P-High.
- 4) D...M, D...H and D...D can sustain full High and Low-side reversal.
- 5) Only available with G3-enclosure. For more details see page 19 and drawing page 24.

IN THE FOLLOWING TABLE THE ESTIMATED INFLUENCE FOR INCREASING STATIC PRESSURE IS GIVEN.

SENSOR	SETPOINT	DEADBAND
P301L-...-D	≈ + 0,1 mbar/bar	≈ + 0,1 mbar/bar
D...L	- 0,7 mbar/bar	≈ - 0,1 mbar/bar
D...M	≈ + 3 mbar/bar	10 mbar/bar
D...H	- 2 mbar/bar	≈ - 0,4 mbar/bar

Example: D...H-type
 Diff. setpoint: 1 bar (1000 mbar)
 If static pressure increases 10 bar Diff.setpoint
 will be (10 x - 2 mbar) = - 20 mbar less = 980 mbar

NOTE: For vacuum differential application consult your BETA Switch Representative.

PRESSURE SWITCHES

3 PROCESS CONNECTIONS

C1 - P304L - **S1N** - B1 - K1 - Y - X2

PROCESS CONNECT SIZE / CODE	AVAILABLE ON SENSOR ²⁾	ALUMINIUM		SS 316		MONEL		BRASS	
		NPT	BSP	NPT	BSP	NPT	BSP	NPT	BSP
1/4" F	F			S1N	S1B			B1N	B1B
	L & M D...L / M	A1N	A1B			M1N	M1B		
	H D...H / D								
1/2" F	F			S2N	S2B			B2N	B2B
	L & M D...L / M	A2N	A2B			M2N	M2B		
	H								
1/2" M	L, M & H D...L / M			S7N	S7B	M7N	M7B		
1/2" Gauge Connection	H L & M				S7G				
Not for vacuum ¹⁾	1" F	L & D...L		S4N	S4B				
	2" F	L & D...L		S6N	S6B			B6N	B6N
	1" M	M & H D...M		S8N	S8B				

Other materials such as P.V.C., Hastelloy, SS 316 Ti, Titanium etc. and other sizes and (Teflon lined) flanged connections are available.

1) **Vacuum switches:** Process conn. size max. 1/2". Vacuum piston & spring (both wetted) standard in SS 316.

2) **Standard process connection for**

"L"ow & "M"edium pressure sensor body	: A1N or A1B
"H"igh pressure sensor body	: S1N or S1B
"F"luid power pressure sensor body	: B1N or B1B
Differential switches: D...H, D...D	: S1N or S1B only
D...L	: A1N or A1B; For Low side only
	High side; Only "L"-sensor connection

NOTES: Process connection according to NACE standards are available, consult your BETA Switch Representative.
NPT connections are tapered; BSP are parallel threaded.

PRESSURE SWITCHES

4 DIAPHRAGM / O-RING

C1 - P304L - S1N - **B1** - K1 - Y - X2

DIAPHRAGM/ O-RING CODE	DIAPHRAGM ⁶⁾		O-RING	USE ¹⁾	DEADBAND MULTIPLIER
B1	Buna-N		Buna-N ²⁾	Standard water / oil (-40 °C bis +80 °C).	1.0
E6	EPDM		EPDM ²⁾	Some hydraulic fluids.	1.0
K5	Kalrez		Kalrez ²⁾	Highly corrosive fluids.	1.5
M1	Monel		Buna-N	Seawater.	2.0
M2			Viton-A ⁵⁾	High temperature NOT below 0 °C. ⁷⁾	
M4			PTFE ⁴⁾	Corrosive acids.	
M5			Kalrez	Highly corrosive and permeative acids.	
N3	Neoprene		Neoprene ²⁾	When required.	1.0
P1	PTFE (Polyimide coated with PTFE)		Buna-N	Oil / air / water.	1.5
P2			Viton-A ⁵⁾	High temperature NOT below 0 °C. ⁷⁾	
P4			PTFE ⁴⁾	Corrosive acids.	
P5			Kalrez	Corrosive acids.	
S1	SS 316		Buna-N	Permeative gases.	2.0
S2			Viton-A ⁵⁾	High temperature NOT below 0 °C. ⁷⁾	
S3			Neoprene	Permeative refrigerant gases.	
S4			PTFE ⁴⁾	Corrosive acids.	
S5			Kalrez	Highly corrosive and permeative acids.	
S6			EPDM	Steam.	
T1	Tantalum		Buna-N	Highly corrosive and permeative gases and non-acid liquids. Select O-ring as required.	2.0
T2			Viton-A ⁵⁾		
T3			Neoprene		
T4			PTFE ⁴⁾		
T5			Kalrez		
V2	Viton-A		Viton-A ^{2) 5)}	High temperature NOT below 0 °C. ⁷⁾	1.5
S0	SS 316	Welded diaphragm	None ³⁾	Highly permeative gases.	3.0
M0	Monel				

1) Wetted parts are suggested for use on the service indicated. However they do not constitute a guarantee against corrosive or permeation since processes varies from plant to plant. Empirical experience by users should be the final guide. The diaphragm/O-ring combinations are for process temperatures of -30 °C to +80 °C, unless otherwise indicated. For process temperatures beyond these limits please contact your BETA Switch Representative.

2) Switches for fluid power applications are limited to these options (O-ring only with SS 316 piston).

3) Only for 1/4" & 1/2" process connections. Not available on vacuum switches. For other sizes and materials, consult your BETA Switch Representative.

4) PTFE O-ring not suitable for vacuum switches or conditions. (Wetted internal spring of Co-Cr-Ni alloy, comparable with Elgiloy).

5) For process temperature > 100 °C, consult your BETA Switch Representative.

6) Other diaphragm materials like Hastelloy available, consult your BETA Switch Representative.

7) High temperature refers to max. 140 °C at processconnection.

DIFFERENTIAL PRESSURE SWITCHES

4 DIAPHRAGM / O-RING

C1 - D352H - S1N - **P1** - K1 - Y - X2



For the Differential Pressure Switches basically the same Diaphragm/O-ring combinations can be used as for the Pressure Switches but we have to consider following.

TYPE	STANDARD	FOLLOWING COMBINATIONS ARE NOT POSSIBLE
P301L-D	B1	S0, M0
D...L	B1	M4, P4, S4, T4, S0, M0
D...M	B1	No Limitation.
D...H	P1	B1, E6, K5, N3, V2,
D...D	P1	M4, P4, S4, T4, S0, M0

Note: Deadband Multiplier for Diaphragm/O-Ring and microswitch element is the same as for pressure switch.

PRESSURE AND TEMPERATURE SWITCHES

5 SWITCHING ELEMENTS VS. ENCLOSURE

C1 - P304L - S1N - B1 - **K1** - Y - X2

SWITCHING ELEMENT		ENCLOSURE				
		G3*, C1, C2, C3, C4, C8	M0	W3, V5	Z1, Z2, Z3, Z4, Z8	
		Internal Earth Terminal	Earth via wired lead	In- & External Earth Terminal		
S. P. D. T. (SINGLE SWITCHING ELEMENT)	SE	3-WAY TERMINAL BLOCK				
	SG					
	SL					4-WAY TERM. BL.
	SP					
	SR					SCREW.TERM.BL.
	G1					4-WAY TERMINAL BLOCK
	K1					
	L1					
	U1					
	V1					
	O1					
N1						
R1				3-WAY TERM. BL.		
M1	3-WAY TERMINAL BLOCK	4-WIRE LEADS	4-WAY TERMINAL BLOCK			
Y1						
Z1						
D. P. D. T. (DOUBLE SWITCHING ELEMENT)	M2	6-WAY TERMINAL BLOCK	7-WIRE LEADS	7-WAY TERMINAL BLOCK		
	Y2					
	Z2					
	G2	6-WAY TERMINAL BLOCK				
	H2					
	K2					
	U2					
O2			7-WAY TERMINAL BLOCK			
N2						
AIR RELAY	SA ** SB **	1/4 NPT. (F) CONNECTIONS				



POSSIBLE

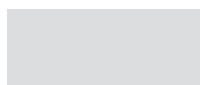

NOT PRACTICAL



NOT POSSIBLE

The standard switching elements are:

"K1" for C-, V- and W- enclosures.

"M1" for M- enclosures.

"R1" for Z- enclosures.

* "G3" enclosure : Only with L1-, K1- or G1-microswitch.
: Wire leads.
: No Internal Earth Terminal.

** "SA" / "SB" only with C1- / C8-enclosure.

PRESSURE AND TEMPERATURE SWITCHES

5 SWITCHING ELEMENTS

C1 - P304L - S1N - B1 - **K1** - Y - X2

SWITCHING CODE	1)	USE	MAX. RATINGS (RES.)		DEADBAND MULTIPL.	
			VAC.	VDC	S.P.D.T.	D.P.D.T.
K1	4)	Standard.	480 / 15A	28 / 0,5 A**	1.0	1.5
L1	4)	Standard for P/D301L & P/D302L ranges.	480 / 10A	28 / 0,5 A	1.0	-
M1	*	Standard on M-Series.	250 / 5A	30 / 0,1 A**	1.5	3.5
U1		Normal DC-service.	480 / 15A	125 / 0,5 A	2.5	4.0
V1		DC-service High DC cap. magnetic blow out.	125 / 10A	125 / 10 A	4.0	-
G1	4)	Low voltage circuit (Gold contacts) For use in H ₂ S environment and/or for (EEx)i applications.	125 / 1A	28 / 0,5 A**	1.5	2.0
Y1	*		125 / 0,1A	30 / 0,1 A	3.0	4.5
O1	*	Gold contacts Environmental proof (IP 67).	250 / 0,1A	30 / 0,1 A	1.5	3.0
N1	*	Silver contacts Environmental proof (IP 67).	250 / 2A	30 / 2 A	1.5	3.0
Z1	*	For higher (amb.) temp. Elgiloy spring. For corrosive environment.	250 / 5A	125 / 0,3 A	3.0	4.5
R1		Ex. Proof ATEX approved. Only in Z-Series.	250 / 5A	250 / 0,25A	3.0	S.P.D.T. only
SP	Adjustable deadband	Small adjustable deadband.	250 / 15A	-	1 to 3	
SR		Wide adjustable deadband.	480 / 20A	-	2 to 6	
SE	3)	Manual reset Actuates automatic on increasing pressure.	480 / 15A	125 / 0,5 A	1.5	
SG	3)	Manual reset Actuates automatic on decreasing pressure.	480 / 15A	125 / 0,5 A	1.5	
SL	5)	Herm. sealed (Inert gas filled) Dusty, corrosive environment.	125 / 1A	28 / 15 A	5.0	
SA	3)	Pneumatic 7)	Normally closed (NC).	For use in explosive atm. Ex II 2G c T6 KEMA 04ATEX4060	Consult BETA Switch Rep.	
SB	3)		Normally open (NO).			

1) For D.P.D.T. action second code figure to be specified as "2" (Example: K1=S.P.D.T./K2=D.P.D.T.).

2) Capacitive and/or inductive load may influence the setpoint repeatability.

3) Not on Differential pressure switches (except for "SR"-micro in "V"- and W-enclosure).

4) VDE certified acc. to. DIN EN 61 058-1:1992+A1:1993.

5) "SR"-and "SL"-micro may influence the low end of range.

6) "SR"-micro in combination with metal diaphragm: standard with option "P".

7) For pneumatic element ask for our separate Air Relay documentation.

* Subminiature.

** DC rating not U.L. listed. From tests and/or experience is known that microswitches have DC capacity. Consult your BETA Switch Representative.

PRESSURE SWITCHES

6 OPTIONS

C1 - P304L - S1N - B1 - K1 - **Y** - X2

OPTION CODE	DESCRIPTION
B	Industrial cleaning of "wetted" parts for oxygen services.
C	Cable gland (weather proof IP65, EExe, EExi or EExd in acc. with classification of enclosure).
I	Intrinsically safe application (EEx)i. Only on "C"-Series.
M	Vacuum protection plate (Not on Vacuum-, Fluid Power-, D...H- and D...D Switch) (Standard on D...L) (Std. SS 316).
P	Recommended on strong process pulsations. Only on "H"-Sensors. Not in combination with EPDM, Neoprene, Viton-A and Kalrez diaphragms.
S	Stainless steel Tag-clipped to enclosure. Tag has 3 lines (20 characters per line).
V	Fungicidal varnish coating (internal).
Y	Epoxy coating of switch (external). Only in combination SS 316 process connection.
D	Differential execution on G3-enclosure. Only for G3-P301L...D.

Tag no. space on nameplates ___ added free of charge

Standard nameplate C.-Series : 2 lines with 18 characters or spaces + 1 line with 14 characters or spaces
 M.-, V.- and W.-Series : 1 line with 18 characters or spaces
 Z.-Series : 1 line with 14 characters or spaces

7 SPECIALS

C1 - P304L - S1N - B1 - K1 - Y - **X2**

We can incorporate numerous specials to meet your requirements. These special requirements are indicated by the letter X in the model code or at the end of the model number, followed by a figure showing the number of specials.

Example:

"X1" at the end of model reference means one special.

"X2" at the end of model reference means two specials have been incorporated.

Details of each special must always be specified completely on enquiries and orders.

Example of specials for BETA switches are:

- Flanged connection 3 /4" to 3" (ANSI or DIN).
- Range indication in Pa, Kg/cm², mm H₂O or mm Hg.
- Breakwire resistor acc E12 range for line monitoring.
- Hirschmann or Harting Connector.
- Moisture inhibitor
- Chemical seal

SELECT YOUR BETA SWITCH

1 ENCLOSURE

W3	-	P506H	-	S1B	-	S2	-	K1	-	Y	-	X2
----	---	-------	---	-----	---	----	---	----	---	---	---	----

See section **1. Enclosure** on page 5.

2 RANGE

W3	-	P506H	-	S1B	-	S2	-	K1	-	Y	-	X2
----	---	-------	---	-----	---	----	---	----	---	---	---	----

See section **2. Range** on page 6, and 7.

3 PROCESS CONNECTIONS (Material/Size/Thread)

W3	-	P506H	-	S1B	-	S2	-	K1	-	Y	-	X2
----	---	-------	---	-----	---	----	---	----	---	---	---	----

See section **3. Process connections** on page 8.

4 DIAPHRAGM / O-RING

W3	-	P506H	-	S1B	-	S2	-	K1	-	Y	-	X2
----	---	-------	---	-----	---	----	---	----	---	---	---	----

See section **4. Diaphragm / O-ring** on page 9 and 10.

5 SWITCHING ELEMENTS

W3	-	P506H	-	S1B	-	S2	-	K1	-	Y	-	X2
----	---	-------	---	-----	---	----	---	----	---	---	---	----

See section **5. Switching Elements** on page 11 and 12.

Selection of your switch is now completed.

If required: For "Optional" and "Special" accessories

Options: See section "**6. Options**" on page 13.

Specials: See section "**7. Specials**" on page 13.

TEMPERATURE SWITCHES

BETA TEMPERATURE SWITCH



The BETA Temperature Switch is a pressure switch incorporating a sealed 2-phase (vapour/liquid) temperature sensor. When the temperature of the process increases, the vapour pressure of the liquid also increases. If this vapour pressure exceeds the pre-adjusted setpoint of the "pressure" switch, it will actuate the switching element.

- Available as direct- or capillary mount sensor.
- In weathertight and explosion proof execution (ATEX approved).
- Fits into most standard thermowells.
- No need for ambient temperature compensation (no setpoint shift).
- Excellent repeatability/small dead-band.
- All 316 stainless steel sensor and capillary (SS armoured).
- Filling system of gas/liquid acc. to SAMA-Class II C.

"C"-Series with Capillary type sensor

EXPLOSION-PROOF TEMPERATURE SWITCH



ATEX approved up to the highest classification
With the "M"-, "V"-, "W"- and "Z"-enclosures
the BETA Temperature Switch is approved by ATEX,
standard NEN EN 50 014 / 018 / 019 / 020 / 281

"W"-Series with Direct mount type sensor

TEMPERATURE SWITCHES

1 ENCLOSURE

C1 - T548 - D00 - S0 - Y - X2

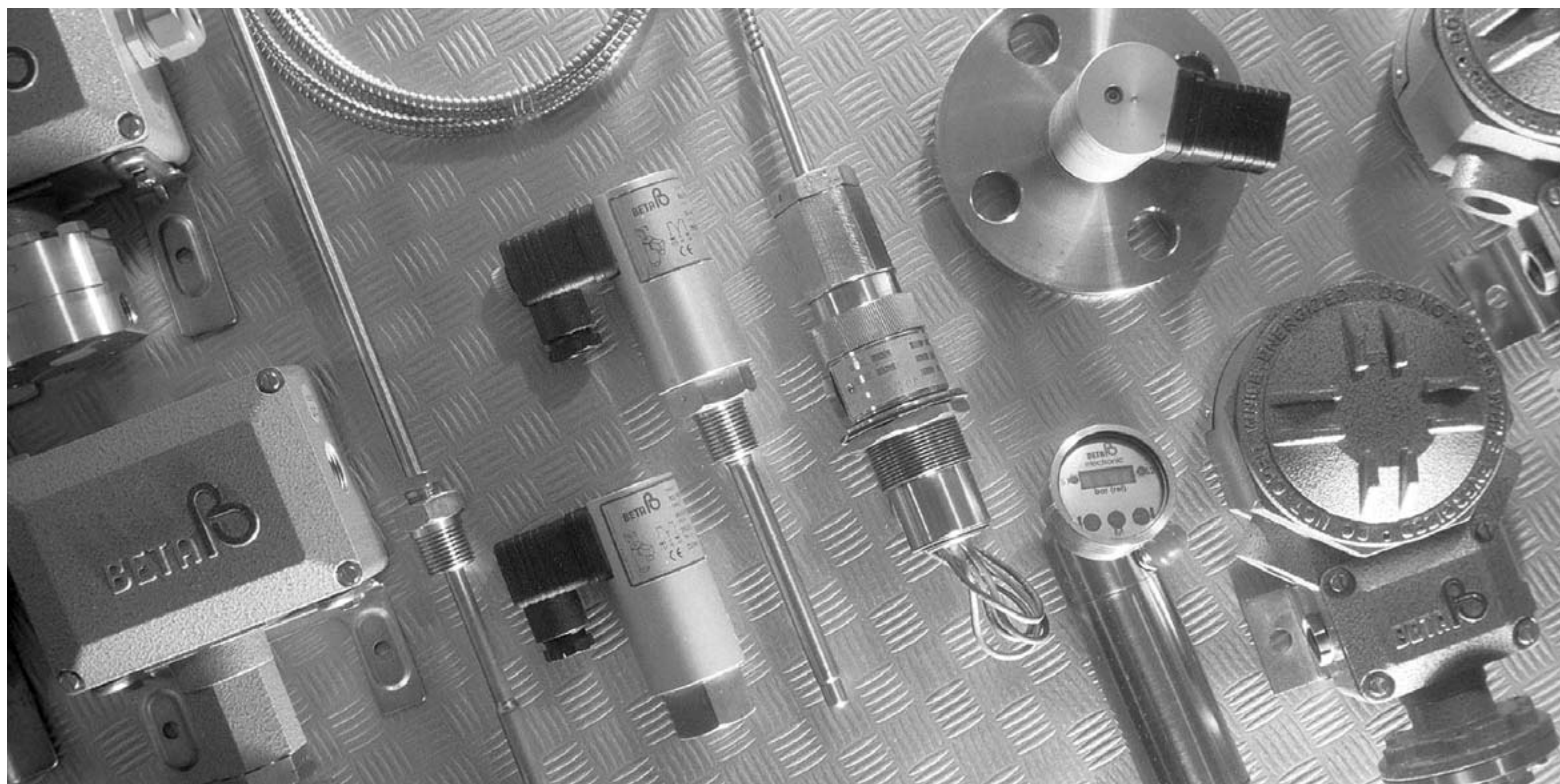

ENCLOSURE CODE	CLASSIFICATION	ELECTRIAL COND. CONN.	MATERIAL	EARTH TERMINAL	TERM. BLOCK
B2	Weathertight Miniature (IP65)	Hirschmann Plug conn. DIN 43650-A	Aluminium	Standard (Via plug)	Not applicable
C1	Weathertight (IP66)	PG 13,5	Aluminium	Standard (Internal)	Standard
C2		M20 x 1,5			
C3		3/4" NPT (F)			
C4		1/2" NPT (F)			
C8		M20 x 1,5	SS 316 1)		
M0	Miniature Explosion-proof EEx ed IIC T6 (IP65) 02 ATEX 2189X	Wire leads (0,5m)	SS 316 1)	Standard (Wire lead 0,5m)	Not applicable
W3	Explosion-proof EEx d IIC T6 (IP65) 02 ATEX 2186X	3/4" NPT (F)	Aluminium	Standard In- & External	Standard
V5		M20 x 1,5	Cast Iron 1)		
Z1	Explosion-proof EEx ed IIC T6 (IP65) 02 ATEX 2187X	PG 13,5	Aluminium	Standard In- & External	Standard EEx e
Z2		M20 x 1,5			
Z3		3/4" NPT (F)			
Z4		1/2" NPT (F)			
Z8		M20 x 1,5	SS 316 1)		

1) See separate brochure BETAMINI for Ranges, Process Connections etc.
Enclosure "B2" only available with Range codes P...H, P...F and V...H.

TEMPERATURE SWITCHES

2 RANGES

C1 - **T548H** - D00 - S0 - Y - X2

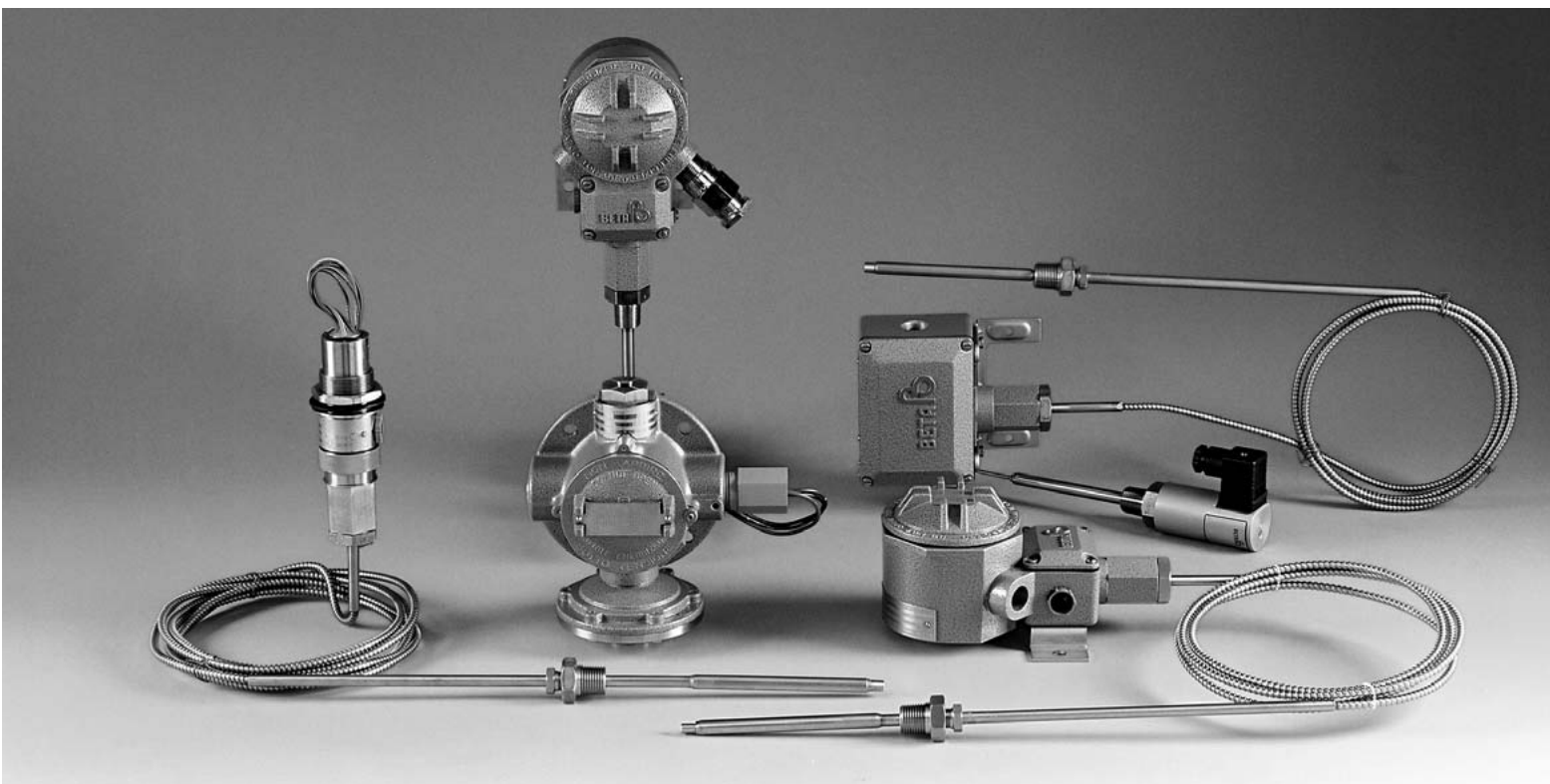

RANGE CODE	ADJUSTABLE RANGE	MAX. DEADBAND ³⁾	MAX. TEMPERATURE	PROOF TEMPERATURE	MAX. PROCESS PRESSURE
T 528 H	- 40 / + 40 °C	3 °C	+ 125 °C	+ 200 °C	175 bar
T 548 H	0 / + 95 °C		+ 180 °C	+ 200 °C	
T 568 H ¹⁾	+ 60 / + 180 °C		+ 300 °C	+ 350 °C	
T 588 H ²⁾	+ 160 / + 300 °C	3,5°C	+ 400 °C	+ 450 °C	

1) In case process temperature > 140 °C, Direct mount sensing bulb is not recommended.

2) Not in combination with Direct mount sensing bulb.

3) For deadband calculation in combination with "SR"- and "SP"- micro, Consult Factory.

TEMPERATURE SWITCHES

3 SENSOR BULB

C1 - T548H - **D00** - S0 - K1 - Y - X2

PROCESS CONNECTION	SENSOR CODE	TYPE OF TEMPERATURE SENSING BULB.	
1/2"NPT (M)	D00	Direct mount.	128 mm length.
	D02		225 mm length.
	C02	Capillary mount.	2 m. capillary length.
	C03		3 m. capillary length.
	C05		5 m. capillary length.
	C10		10 m. capillary length.
	CXX		Special capillary length.

All SS 316 stainless steel sensor, capillary (SS 304 armoured) and compression fitting.

1) Not in combination with range T588H (+160/+300 °C), not recommended with T568H in case of process temperature >140 °C.

2) Length of capillary should be specified, consult your BETA Switch Representative.

4 DIAPHRAGM / O-RING

C1 - T548H - D00 - **S0** - K1 - Y - X2

All temperature switches have "S0" welded diaphragm.

5 SWITCHING ELEMENTS

C1 - T548H - D00 - S0 - **K1** - Y - X2

The standard Switching elements are: "K1" for C -, V - and W - enclosures

"M1" for M - enclosures

"R1" for Z - enclosures

Deadband Multiplier microswitch element same as for pressure switch.

For other available switching elements / and more technical information see **5** on pages 11 and 12.

TEMPERATURE SWITCHES

6 OPTIONS

C1 - T548H - D00 - S0 - K1 - **Y** - X2

OPTION CODE	DESCRIPTION
C	Cable gland (weather proof IP65, EExe, EExi or EExd in acc. with classification of enclosure).
I	Intrinsically safe application (EEx)i. Only on "C"-Series.
S	Stainless steel Tag-clipped to enclosure. Tag has 3 lines (20 characters per line).
V	Fungicidal varnish coating (internal).
Y	Epoxy coating of enclosure and sensorbody (external).

Tag no. space on nameplates __ added free of charge

Standard nameplate C.-Series : 2 lines with 18 characters or spaces + 1 line with 14 characters or spaces
M.-, V.- and W.-Series : 1 line with 18 characters or spaces
Z.-Series : 1 line with 14 characters or spaces

7 SPECIALS

C1 - T548H - D00 - S0 - K1 - Y - **X2**

We can incorporate numerous specials to meet your requirements. These special requirements are indicated by the letter X in the model code or at the end of the model number, followed by a figure showing the number of specials.

Example:

"X1" at the end of model reference means one special.

"X2" at the end of model reference means two specials have been incorporated.

Details of each special must always be specified completely on enquiries and orders.

BETA EXPLOSIONPROOF SWITCHES

The most complete range of Explosion-proof switches !

The BETA Pressure & Temperature Switch programme offers you the most complete range of Explosion-proof switches for virtually every industry and application.

The "BETA Switch", well known as a safety instrument, adds an extra dimension to industrial safety by having the switches approved up to the highest classification EEx d IIC T6/T5 by KEMA 02ATEX.

- Quality product (Q.A. acc. to ISO 9001-2000).
- "User Friendly" Modifications – Standard features incorporated for your safety.
- Only 3 process wetted parts – Check with us before considering expensive Chemical Seals.
- Very high overrange pressures – No setpoint shift.
- "Designed-in" reliability – Designed for your application.
- Wetted parts to NACE standard available.

M-Series (Ex II 2G EEx ed IIC T6)



"MINEX"-Series

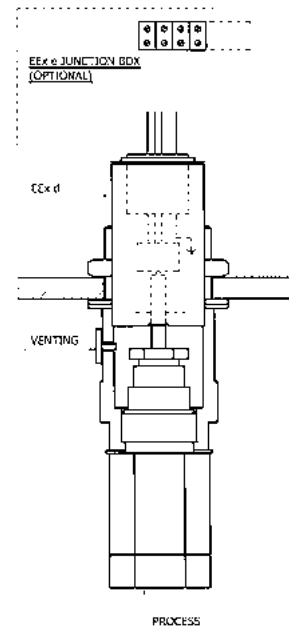

"M"-Series (Ex II 2G EEx ed IIC T6)

The stainless steel Mini Explosion-proof switch "M"-series is specially designed for Offshore application.

ATEX approved: KEMA 02 ATEX 2189 X (EN 50 014 / 018 / 019)

(-20 °C to +40 °C / T6)

- Available as Pressure-, Hydraulic-, Vacuum-, Differential Pressure (only "D...L" and "D...H"-serie) and Temperature switch.
- All ranges (except for P301L and P302L) available.
- S.P.D.T. and D.P.D.T. execution available.
- Highest overrange protection.
- Combined, easy installation in (optional) EExe box (Min. installation space).
- Easy field adjustment.

BETA EXPLOSIONPROOF SWITCHES

V- and W-Series (Ex II 2G/D EEx d IIC T6/T5)*



"W"-Series

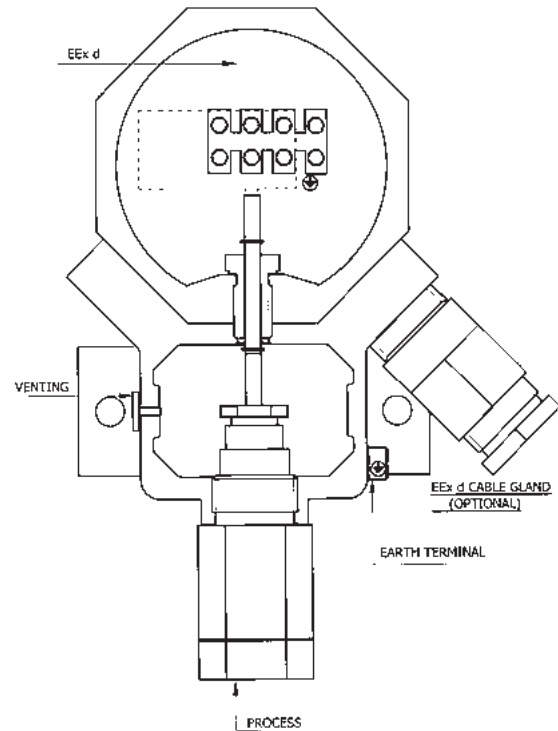

"W"-Series (Ex II 2G/D EEx d IIC T6/T5)*

The "V" and "W"-series are a worldwide best seller.

With its separate adjustment compartment enabling easy field calibration.

Due to the wide selection of materials and components parts, virtually all applications can be covered.

ATEX approved: KEMA 02 ATEX 2186 X (EN 50 014 / 018 / 281)

* For Gas : Ex II 2G EEx d IIC T6 (-40 °C to +40 °C)

: Ex II 2G EEx d IIC T5 (-40 °C to +80 °C)

For Dust : Ex II 2D T 100 °C

- In aluminium ("W"-type) or cast iron ("V"-type).
- With separate adjustment -compartment.
- Available as Pressure-, Hydraulic-, Vacuum-, Differential pressure- and Temperature switch.
- All ranges available.
- Highest overrange protection.
- Excellent for field mounting. (2" Pipe mounting bracket as accessories available)
- Heavy duty execution.

BETA EXPLOSIONPROOF SWITCHES

Z-Series (Ex II 2G EEx ed IIC T6)

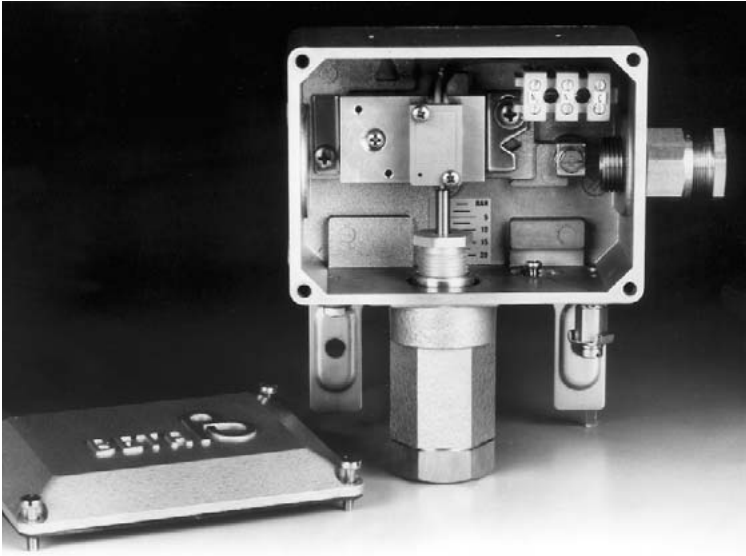

"Z"-Series

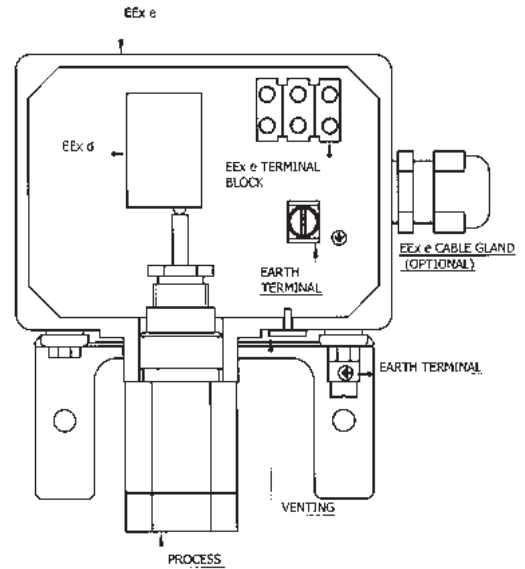

"Z"-Series (Ex II 2G EEx ed IIC T6)

The "Z"-Series, the economical explosion-proof switch.
ATEX approved: KEMA 02 ATEX 2187X (EN 50 014 / 018 / 019)
(-40 °C to +65 °C / T6)

- Available in Aluminium or SS 316 (For offshore applications).
- Available as Pressure-, Hydraulic-, Vacuum-, Differential pressure (not on "D...D"-serie) and Temperature switch.
- All ranges (except for P301L and P302L) available.
- Limited to "R1" switching element. (S.P.D.T. only).
- High overrange.
- Simple and quick electrical connection.

BETA EXPLOSIONPROOF SWITCHES - INTRINSIC SAFE



"C"-Series

BETA "C" - Series with option "I" for intrinsically safe systems

BETA has its "C"-Series switches with option "I" certified by KEMA acc. to NEN EN IEC 60079-0 / EN 50 020 for **Ex II 1G/D EEx ia IIC T6 T 85 °C** or **Ex II 2G/D EEx ib IIC T6 T 85 °C**.

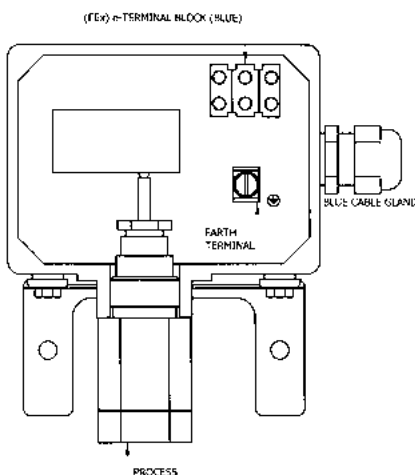

ATEX approved: KEMA 02 ATEX 1190X
(EN 50 014 / 020 / 281 / 284)
(-40 to +80°C)

This option includes all required installation materials like a blue coloured EEx e approved terminal block and the - (standard) earth - terminal.

Option "I" in accordance with art. 9 of the ATEX Directive 94/9/EC (EEx ia/ib IIC) which are related to insulation, clearance, creepage distances and enclosure type whereby a max. peak voltage of 90 V / 3,3A is allowed.

"C"-Series (Intrinsically safe application EEx i).

Please note following:

When switch is ordered with cable gland (option "C") we will automatically install the EEx i blue cable gland (see also drawing). Due to low current used in I.S. systems we recommend the use of switching elements with gold contacts (code "G1", "O1" or "Y1"). It is not mandatory.

BETA DIFFERENTIAL PRESSURE SWITCHES

The "USER FRIENDLY" generation of BETA switches offers you a complete range of Differential Pressure Switches

VERY LOW RANGE

"P301L - .. - D"-SERIE

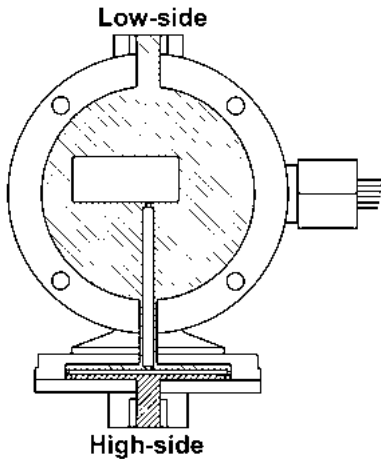

- Principle:** As pressure switch in sealed. Aluminium enclosure.
- Range:** 2-15 mbar.
- Max. Static Pressure:** 10 bar.
- Application:** Dry clean air or inert gases (Low side only).
- Execution:** Weathertight IP 66. (G3 enclosure only) with potted wire leads.

LOW RANGE

"D... L"-SERIE

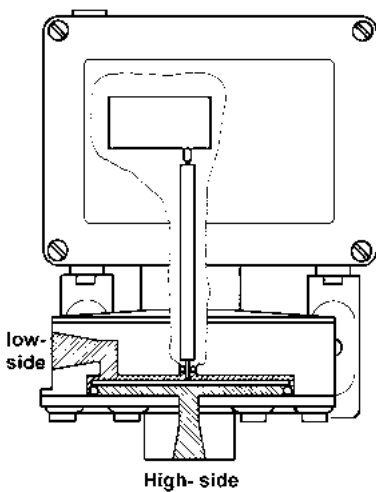

- Principle:** As pressure switch, with sealed Aluminium sensorbody (optional in SS 316).
- Range:** 12 - 1250 mbar.
- Max. Static Pressure:** 30 bar.
- Application:** Dry clean air, inert gases and clean non-corr. fluids and gases.
- Execution:** Weathertight IP 66 (C-enclosure).
 EEx i a/b (C-enclosure + option I).
 EEx ed (M-enclosure).
 EEx d (V- and W-enclosure).
 EEx ed (Z-enclosure).

GENERAL PURPOSE

"D... M"-SERIE

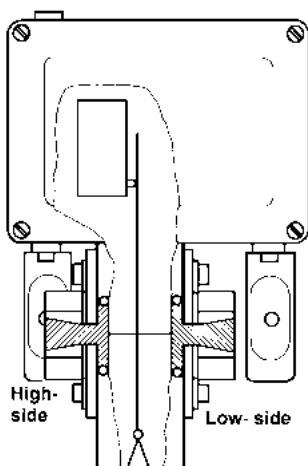

- Principle:** 2 x piston/diaphragm type with separate sealing for High and Low.
- Range:** 0,3 – 70 bar.
- Max. Static Pressure:** 140 bar.
- Application:** All fluids & gases provided acceptable choice of wetted parts is within our range.
- Execution:** Weathertight IP 66 (C-enclosure),
 EEx i a/b (C-enclosure + option I),
 EEx ed (Z-enclosure),
 EEx d (V- and W-enclosure).

BETA DIFFERENTIAL PRESSURE SWITCHES

LOW RANGE / HIGH STATIC "D... H"-SERIE

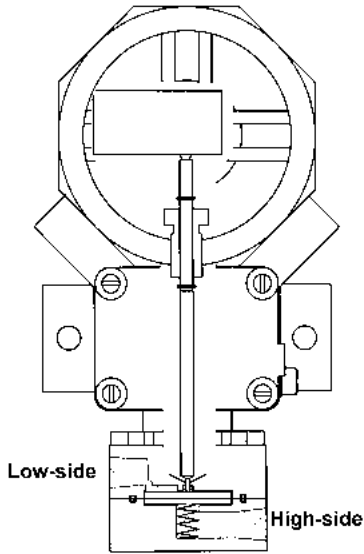

Principle:

Piston type with single diaphragm, sealed in SS 316 sensorbody.

Range:

80 – 3450 mbar.

Max. Static Pressure: 200 bar.

Application:

Clean fluids and gases*, provided acceptable choice of wetted parts is within our range.

Execution:

Weathertight IP 66 (C-enclosure),
 EEx i a/b (C-enclosure + option I),
 EEx ed (M-enclosure),
 EEx d (V- and W-enclosure),
 EEx ed (Z-enclosure).

LOW RANGE / HIGH STATIC "D... D"-SERIE

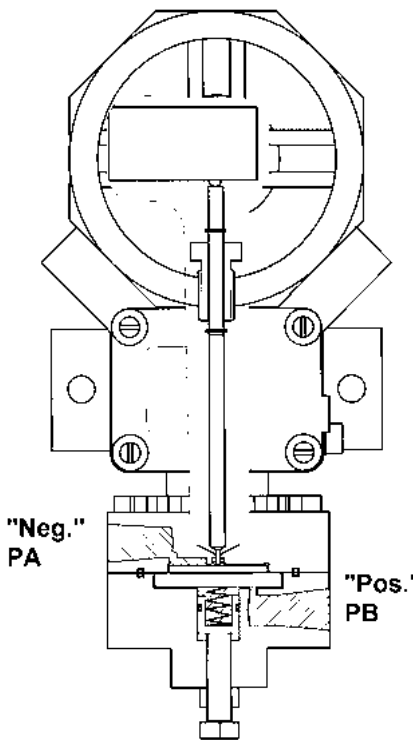

Bi-Directional Differential Pressure Switch

Principle:

Piston type with single diaphragm, sealed in SS 316 sensorbody.

Range:

0,1 – 3,5 bar

Max. Static Pressure: 200 bar

Application:

Clean fluids and gases*, provided acceptable choice of wetted parts is within our range.

Typical application:

Natural gas pipelines, safe guarding high pressure pipeline valves against being opened at too high differential pressure from either side.

Execution:

Weathertight IP 66 (C-enclosure),
 EEx i a/b (C-enclosure + option I),
 EEx d (V- and W-enclosure).

* With "clean fluids and gases", we mean free of particles > 40µm, filters (not included) are recommended in case of contaminated medium. A differential pressure switch is a "dead end" instrument, so a simple filter with fine mesh will do.

BETA PRESSURE & TEMP. SWITCH - CERTIFICATIONS

EXPLOSIONPROOF CERTIFICATIONS

- ATEX – EEx d IIC T6 for V- and W-Series.
- ATEX – EEx ed IIC T6 for M- and Z-Series.
- ATEX – EEx ia/ib IIC T6 for C-Series (intrinsically safe).
- ATEX – EEx II 2 G c T6 for Air Relay SA/SB.

And more available for different countries like Japan, Korea, South-Africa, Australia etc..

MARINE APPROVALS

- Rina for B- and C-Series
- G.L. for C-Series

FOR GAS, FUEL, WATER AND STEAM

- DVGW - C-, V- and W-Series
- DGWK - C-, V- and W-Series
- TÜV 100/1 - C-, V-, W- and Z-Series

More certificates/reports are available. Please consult your BETA Switch Representative.



DIMENSIONS

"C."- & "Z."-Series: Pressure & Vacuum

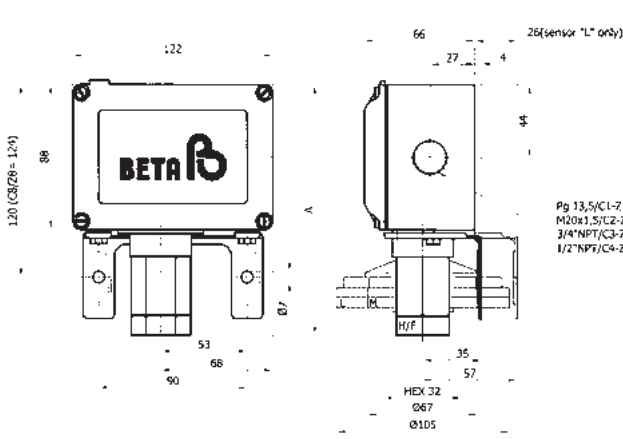

TYPE	SENSOR	A
PRESSURE SWITCH	L	152
	M	152
	H	152
	F	160
VACUUM SWITCH	L	173
	M	173
	H	164

"W."-Series: Pressure & Vacuum

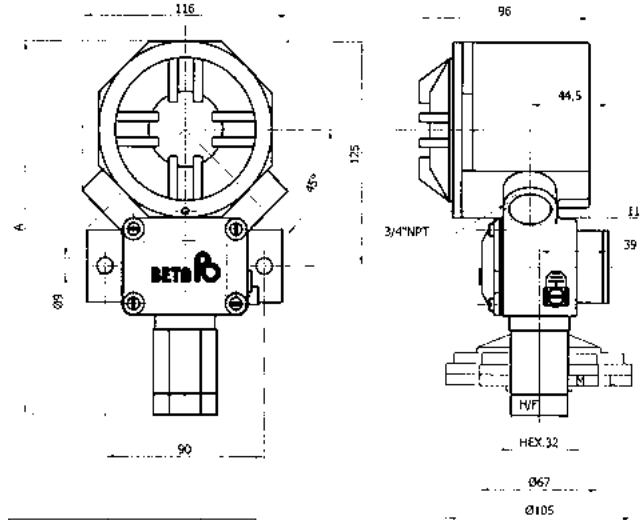

TYPE	SENSOR	A
PRESSURE SWITCH	L	207
	M	207
	H	207
	F	215
VACUUM SWITCH	L	228
	M	228
	H	222

"M0"-Series: Pressure & Vacuum

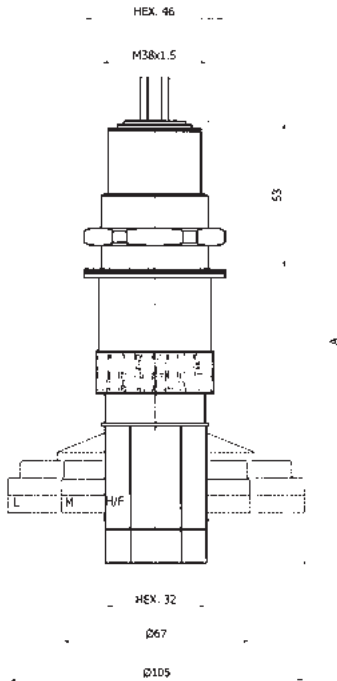

TYPE	SENSOR	A
PRESSURE SWITCH	L	155
	M	155
	H	155
	F	163
VACUUM SWITCH	L	175
	M	175
	H	169

"V5"-Series: Pressure & Vacuum

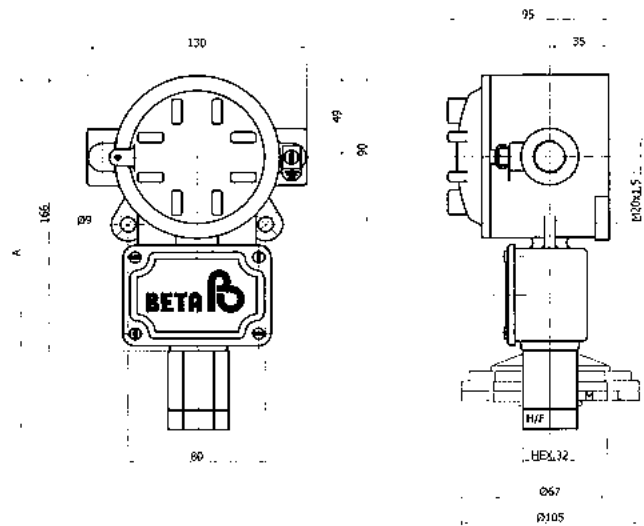

TYPE	SENSOR	A
PRESSURE SWITCH	L	213
	M	213
	H	213
	F	221
VACUUM SWITCH	L	234
	M	234
	H	228

Dimensions given here are for 1/4" and 1/2" (F) process connections: For "H"-sensor with 1/2" (F) add 4 mm on "A" dimension. Sizes in mm, tolerances $\pm 1,5$ mm.

DIMENSIONS

"G3"-Type: Low Differential

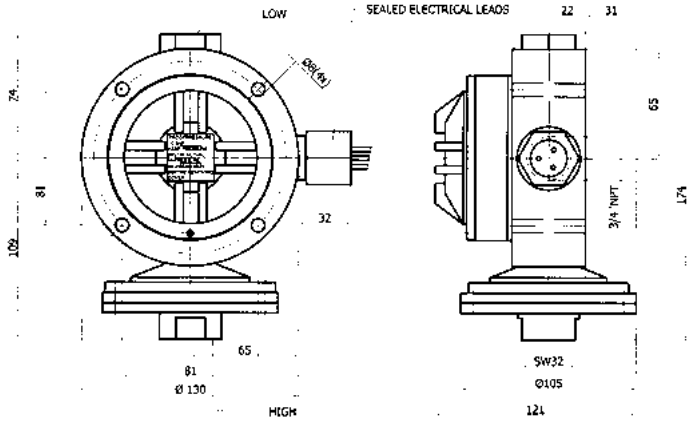

"C."- & "Z."-Series: Differential "D...L"

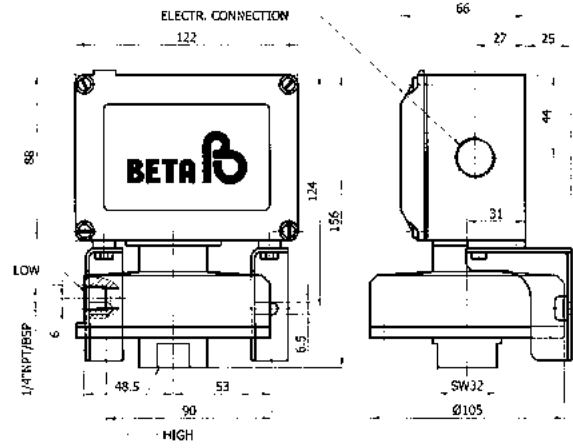

"C."- & "Z."-Series: Differential "D...M"

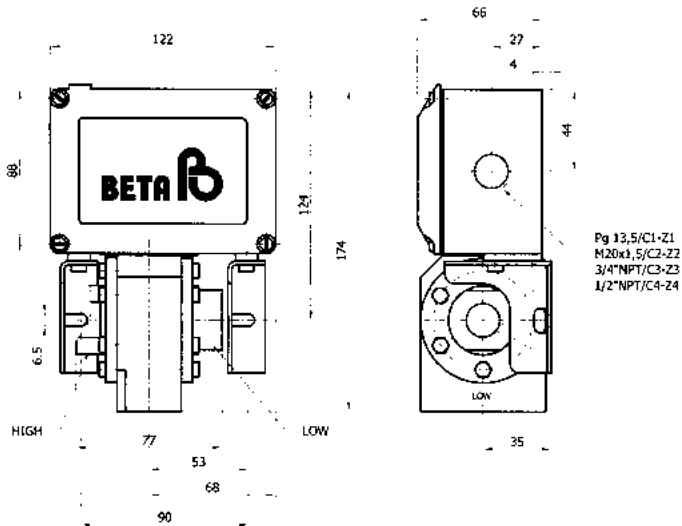

Pg 13,5/C1-Z1
M20x1,5/C2-Z2
3/4" NPT/C3-Z3
1/2" NPT/C4-Z4

"C."- & "Z."-Series: Differential "D...H"

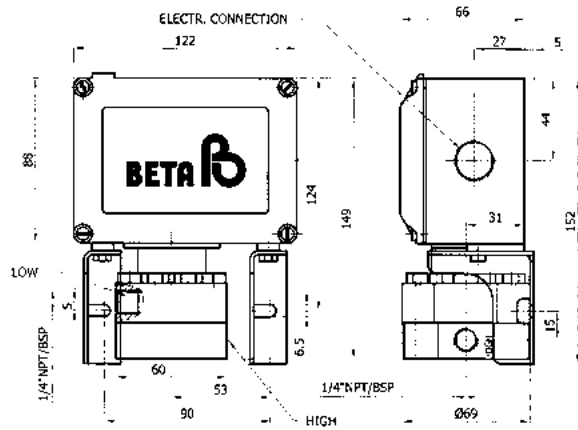

DIMENSIONS

"W."-Series: Differential "D...L"

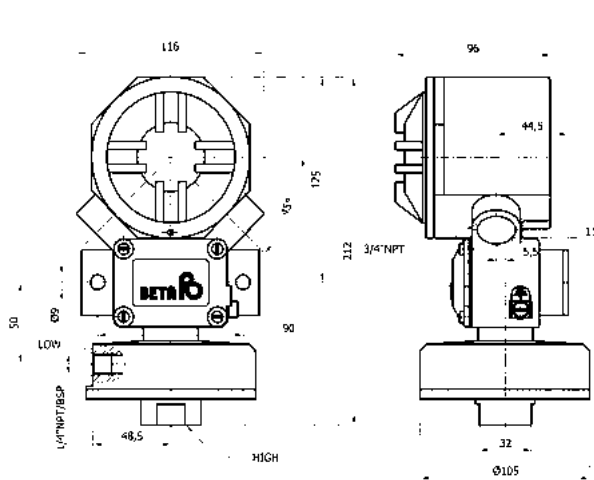

"W."-Series: Differential "D...M"

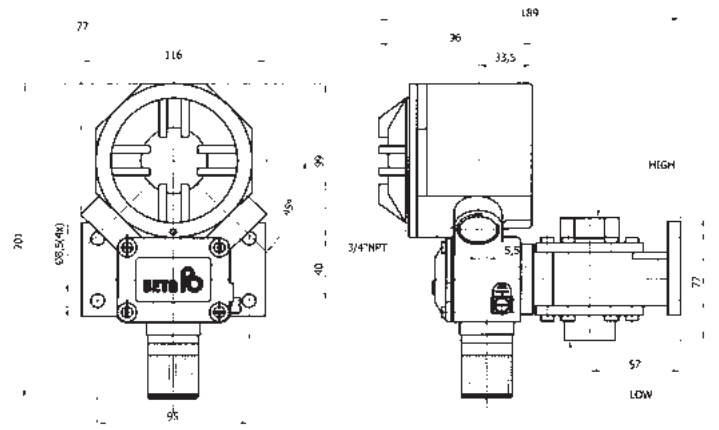

"W."-Series Differential "D...H"

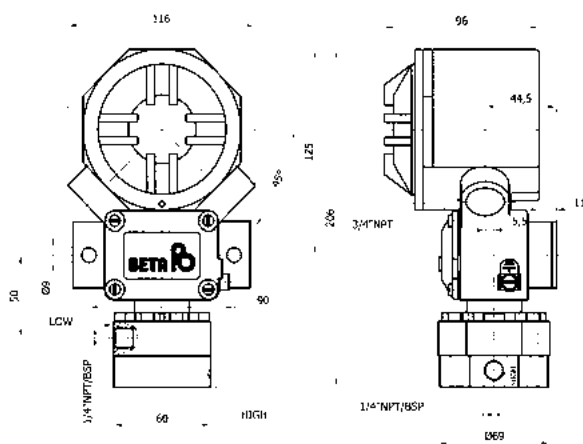

"W."-Series: Differential "D...D"

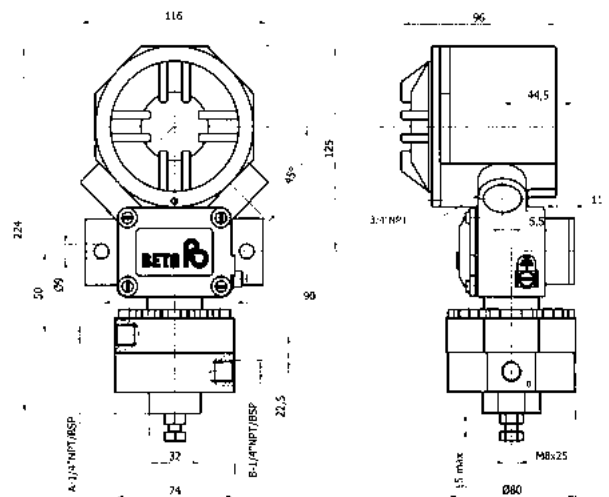

Dimensions given here are for 1/4" and 1/2" (F) process connections: For "H"-sensor with 1/2" (F) add 4 mm on "A" dimension. Sizes in mm, tolerances $\pm 1,5$ mm.

DIMENSIONS

"MO"-Series: Differential "D...H"

"C."- & "Z."-Series: Temperature "Direct" mount

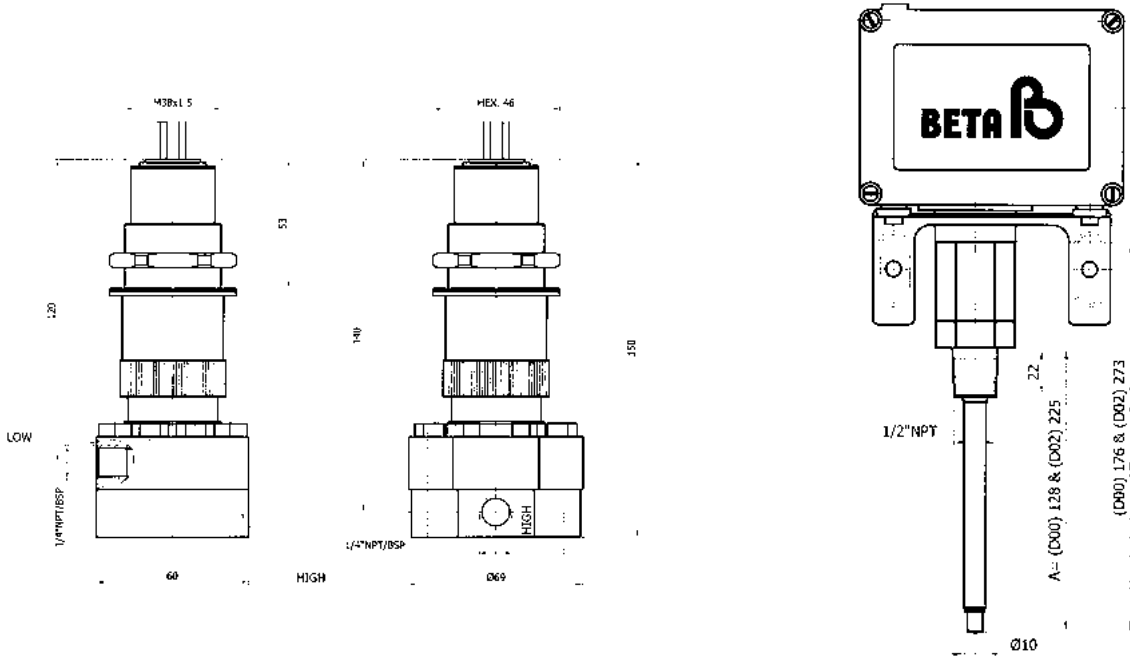

"W."-Series: Temperature "Capillary" mount

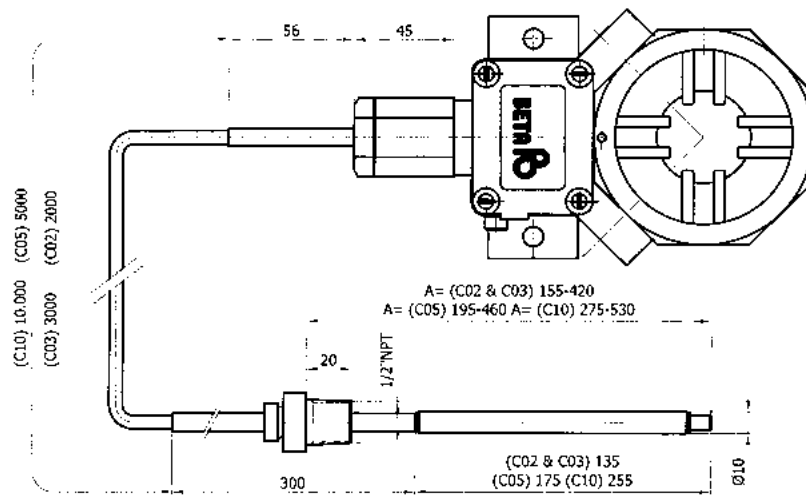

ACCESSORIES

2" Pipe mount bracket (SS 304)

"C."- & "Z."-Series

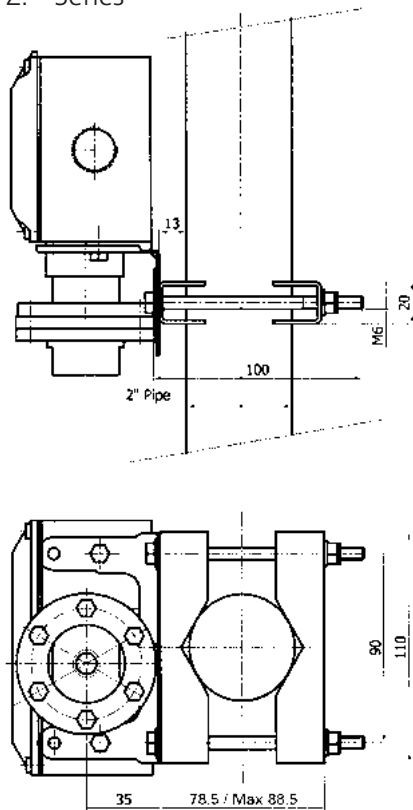

"W."-Series

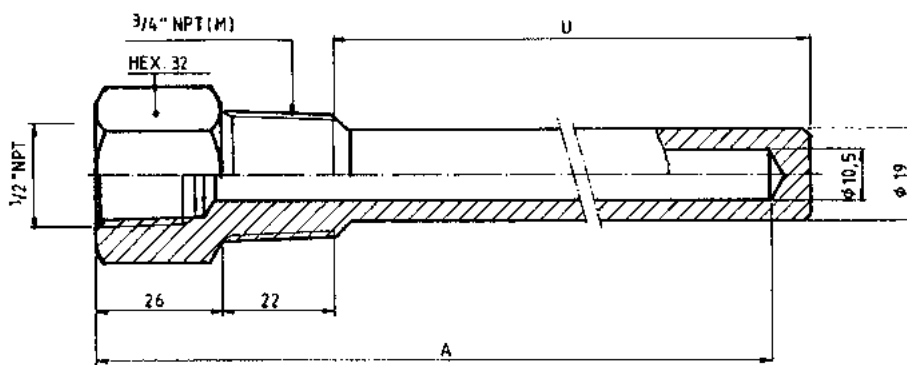
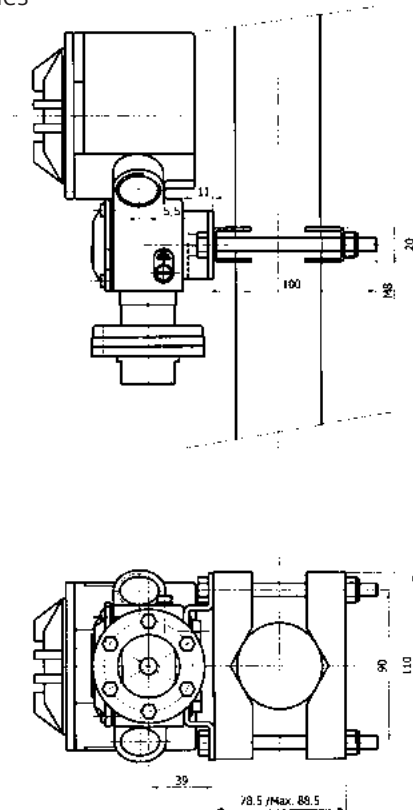

Standard BETA Thermowell

CODE	INSERTION LENGTH U (MM)	INSERTION ELEMENT LENGTH A (MM)	FIT TO BETA TEMP. SENSING BULB
TW 11	115	155	D00, C02, C03
TW 15	155	195	C02, C03, C05
TW 19	190	228	D02, C02, C03, C05
TW 22	228	270	C02, C03, C05, C10

NOTES:

1. "C10" requires special Thermowell. Consult your BETA Switch Representative.
2. BETA Thermowells to be ordered as separate item. Do not include Thermowell code into the switch code.
3. Special Thermowell possible. Consult your BETA Switch Representative.

BETA PRESSURE & TEMPERATURE SWITCHES



"OEM"-switches ("B"-Series)



Weathertight switches ("C"-Series)



Exproof SS 316 offshore switches ("M"-Series)



Explosion proof switches ("W"-Series)



Economical Exproof switches ("Z"-Series)



Air relay switch